

Ultra small size high voltage power supply 500V to 2KV, chassis installing type

2W to 3W adjustable output high voltage power supply

Bellnix® 0V~500V, 1000, 1500V, 2000V SHV Series

The SHV series is the first high voltage power supply in the industry to use the latest SMT (surface mount technology) making the size 1/5 from the original product, with an adjustable output voltage type mid-high voltage DC-DC converter.

The output voltage can be adjusted using an external voltage or external adjustable resistor. The SHV series is a low noise power supply that installing chassis available.

■ Features

- Chassis installing type
- Output voltage 0V to 500 - 2000V
- Output capacity 2W to 3W
- Over current protection
- World's smallest size device
- Low price
- 5 sided metallic shield case
- Low ripple noise of 30mVp-p
- Remote ON / OFF control
- Adjuste by volume or external voltage
- Isolated type between input/output
- High reliability, long life



■ Model name/Rating

Model name SHV Series	Input voltage (Vdc)	Output voltage (Vdc) Note1	Output current (mA)	Load resistance min	Output capacity (W)	Input current (mA) typ	Ripple noise (mVp-p) typ	Case
SHV12 - 0.5K6000P	10.8 to 13.2	0 to +500	0 to 6.0	83.3KΩ	3.0	390	30	S-11
SHV12 - 0.5K6000N		0 to -500						
SHV12 - 1.0K2000P	10.8 to 16.5	0 to +1000	0 to 2.0	500KΩ	2.0	290	30	S-11
SHV12 - 1.0K2000N		0 to -1000						
SHV12 - 1.5K1300P	10.8 to 16.5	0 to +1500	0 to 1.3	1.15MΩ	2.0	290	30	S-11
SHV12 - 1.5K1300N		0 to -1500						
SHV12 - 2.0K1000P	10.8 to 16.5	0 to +2000	0 to 1.0	2MΩ	2.0	340	50	S-11
SHV12 - 2.0K1000N		0 to -2000						

■ Specifications

Input regulation	0.03% typ.(Regulation of input voltage range)
Load regulation	0.03% typ.(Load current 0% to 100%) SHV12-0.5K type is 0.08% typ.
Temp regulation	±0.01%/°C typ.(Temp. regulation -10°C to +50°C)
Over current protection	Hold back characteristic, auto restart circuit operates at 105% or more
Output voltage accuracy	Below ±5%(Rated output, rated load, Vcont=4V)
Output voltage control	External voltage 0V to +4V, or an adjustable resitor with 5KΩ external.
ON/OFF control	Available (Between 2.BLK - 5.BLU : when open=ON, when short=OFF)
Usage temperature range	-10°C to +60°C (Derating required for temp.50°C or higher)
Storage temperature range	-25°C to +85°C
Usage humidity range	20% to 95%RH(Non condensing)
Input/output isolation	Non-isolated type (2.BLK - 6.BLK and case are internally connected.)
MTBF expected value	390,000Hmin.(From Bellnix MTBF formula graph)

Note1: The output voltage can be controlled by impressing the Vcont voltage. Using an adjustable resistor or an external voltage, voltage should be impressed on the Vcont pin in order to control the output voltage. When Vcont voltage=0V, the output voltage(residual output voltage) should be less than 0.5% of the max output voltage (at Input/Output rating).

■ Test circuit

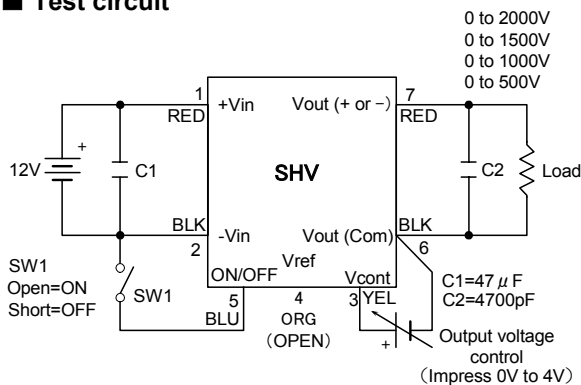

Warning 1: The input-output ground line and case are internally connected.

Warning 2: Vref is 4V±0.3V (When external VR=5KΩ)

Warning 3: The ON/OFF can be controlled with a transistor.

■ Block diagram

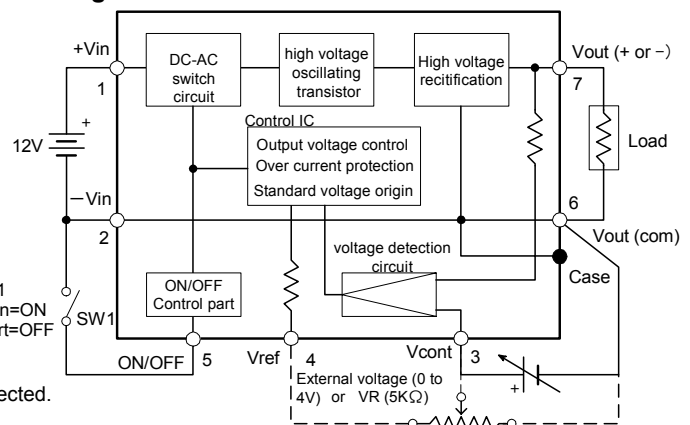

Model/Dimensions/Input-output configuration (S-11 case)

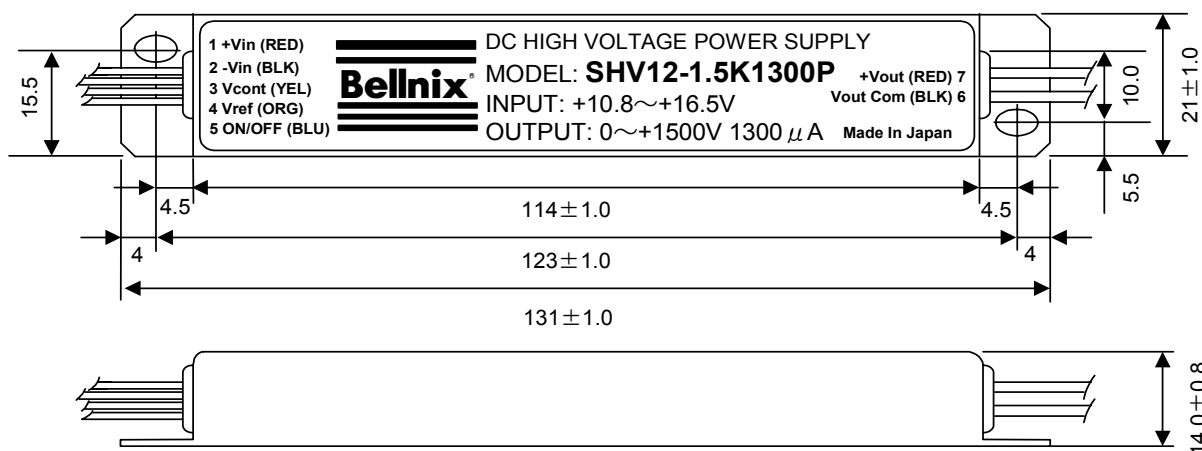

No.	Name/Function	Lead line type
1	+Vin	UL1430#22 (RED)
2	-Vin	UL1430#22 (BLACK)
3	Vcont	UL1430#22 (YELLOW)
4	Vref	UL1430#22 (ORANGE)
5	ON/OFF	UL1430#22 (BLUE)
6	Vout Com	UL1430#22 (BLACK)
7	Vout (+or-)	UL3239#22 (RED)

Note1 : Lead length

Input (1 to 5) : 250mm

Output (6 to 7) : 500mm

Note2 : 5 sided metallic case

Note3 : -Vin and Vout Com, and the case are internally connected.

Weight : 98g typ.

Units : mm

Tolerance unless otherwise specified ±0.5

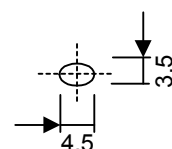

Installation hole dimension

Controlling the output voltage using an adjustable resistor

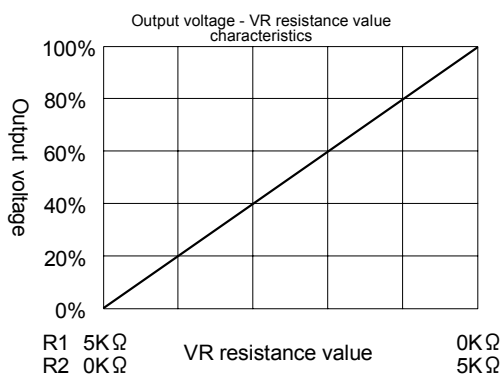
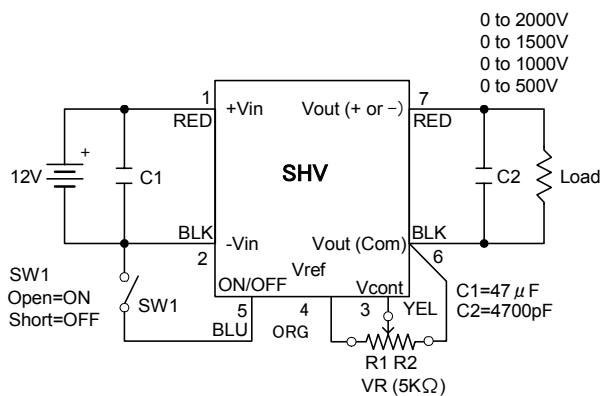

Controlling the output voltage using an external voltage

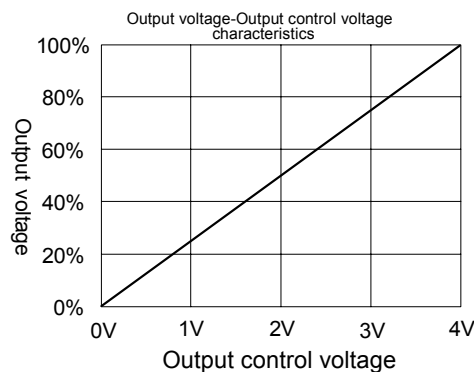
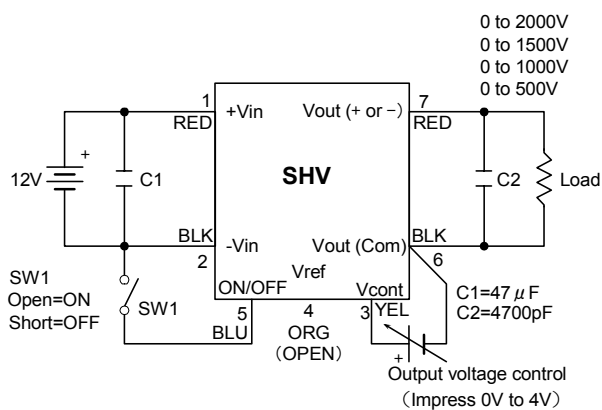

Standard usage instructions

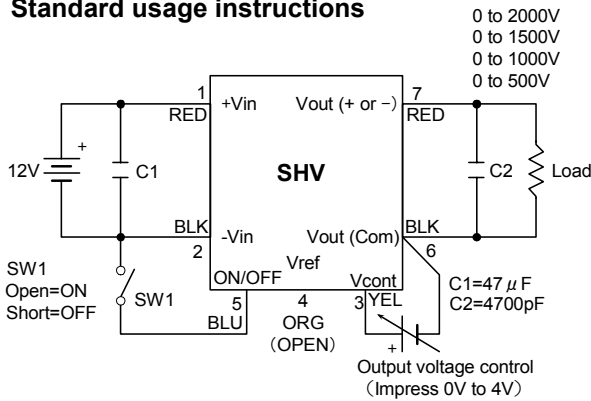

0 to 2000V
0 to 1500V
0 to 1000V
0 to 500V

The SHV series does not require any external parts, however when the impedance is high, for example: the distance between the power supply and converter is long, the input line is thin, or the input side has a filter then connecting a capacitor C1 to the input side is recommended. Place the capacitor as close as possible near to the converter pin side, to lower the lead inductance.

ON/OFF control

By opening and closing between the ON/OFF pin and Vin Com pin the output voltage can be externally turned on and off.

Between the ON/OFF pin (5) and -Vin pin (2)

- 1) Open will turn the output ON
- 2) Short(0 to 1.0V, 1mA max) will turn the output OFF

The ON/OFF pin is internally pulled up to 5V, so be careful of the voltage from the switching element (photo couplers, transistors, etc) of the ON/OFF pin.

Keep open when not using the ON/OFF control.

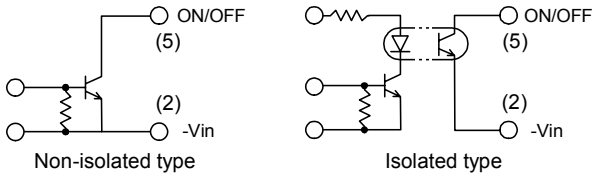

The chattering to the ON/OFF pin will affect the output voltage, so choose one without any chattering. When the output is turned off by ON/OFF control, the residual output voltage should be within 0.5%. (at Input/Output rating)

Over current protection

The SHV series installed the over current protection to protect from the over load and load short. When the product status is in over load or load short mode, the output voltage will be decreased, and once the problem has been removed, the voltage will increase again.

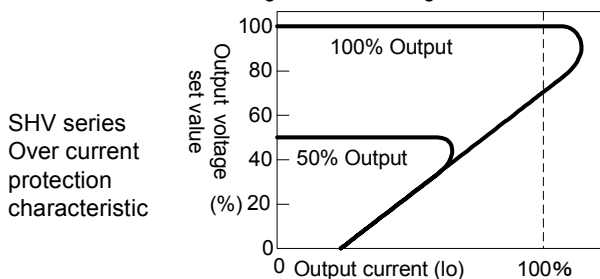

Setting/Adjusting the SHV series

The SHV series output voltage can be adjusted using an external voltage or external adjustable resistor.

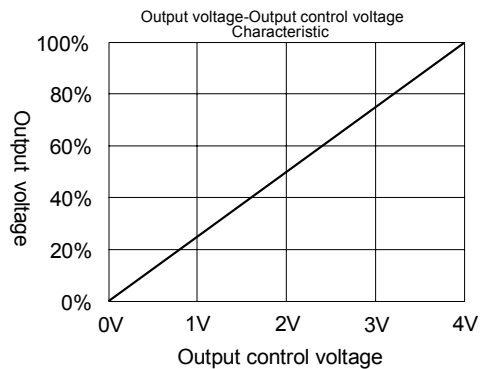
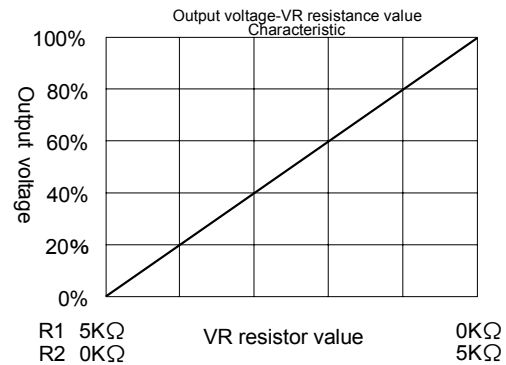
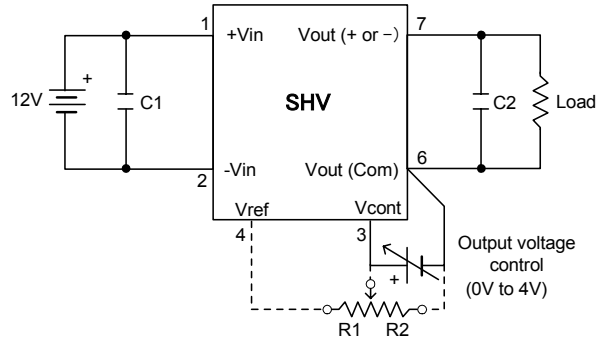

The above characteristics (Output voltage -VR resistor value characteristic) graph is an indication of the resistance value R1 and R2. Please check the output voltage by the adjustable resistor etc. and adjust at the actual using.

Do not impress voltage higher than 4V+5% on the Vcont. Use an adjustable resistor appliance with good temp characteristics.

When the resistance value is 5.0KΩ(R1=0Ω, R2=5KΩ), the max.voltage 4.0V will impress to Vcont pin. Therefore, the margin of error for the resistance value will largely affect the max output voltage, so use the resistance value as 5.0KΩ±5%.

■ Recommended pattern

1) The MHV series uses a metallic case. When mounting to a double-sided PCB, the wiring for the converter should be on the soldering side.

Also, this converter will generate high voltages so the creepage distance should also be taken in when designing.

2) When mounting to a double-sided PCB, the land of the parts side of the high voltage output pin should be as small as possible.

3) The metallic case does not need to be connect to ground. However, when using and ground with the metallic case, make the impedance lower as possible between the ground.

■ Vref pin (Standard voltage output)

When adjusting the output voltage with an adjustable resistor, this pin is used. Vref has a standard output voltage of 4V. In this case, use an external resistor with a resistance of 5KΩ.

The resistance(the margin of error) of external adjustable resistor will affect the setting value of Vref pin voltage, so use a resistor with high accuracy of 5KΩ±5%. The type of adjustable resistor (5KΩ) will not matter, however one with a well temperature coefficient is recommended.

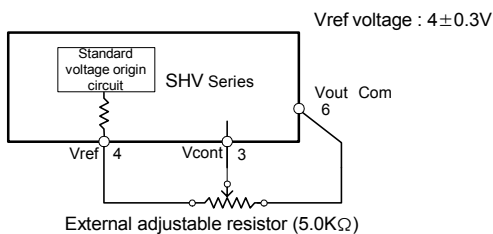

■ Prevention of inverse input connection

The converter may break if the polarities are reversed. If there is a possibility in which the connections maybe reversed, connect a diode and fuse to the input pin like below.

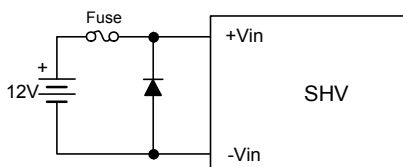

■ Recommended soldering conditions

Soldering conditions for each part is as follows:

- 1) Using a soldering iron 340 to 360°C 5 sec.
- 2) Using a soldering tub 230 to 260°C 10 sec.

■ Lowering the output noise even farther

The MHV series does need any external parts, however to lower the output noise even farther, connect a capacitor C2 like the figure below.

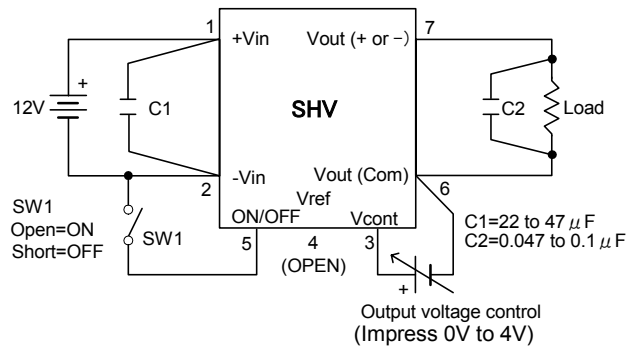

When lowering the output noise even more, keep in mind the input/output wiring, creepage and area distance, while keeping the wiring as thin as possible and layout the C2 near to the Load.

Point!

- 1) When choosing a capacitor that connect to the input, choose one which is a high frequency characteristic capacitor.
- 2) Common pattern should be designed thick and short to make same impedance small.
- 3) The capacitor which is connected to the output side should be able to withstand the pressure, and connect to the load side. At this time, the capacitor lead should be shortened. Also, when the load response time is a problem, please be aware of the time constant.

■ Guarantee

This product shall be guaranteed for year. During this period, if there should be any failure definitely due to our designing or manufacturing, we will repair or replace it with a new one at our expense. However, in any case that the product is modified and/or has made any interal remodlling by the buyer, the product can no longer be guaranteed. This guarantee shall cover only the SHV series.

- If you have any further technical questions for this product, please contact to us.

E-mail: info@bellnix.com
<http://www.bellnix.com>