

Ultra High Efficiency 93% High-speed Response, Step-Down DC-DC Converter

20 Watt BSV-A Series

Bellnix®

BSV series is a small size (33x21.5x6mm size) and light weight (4g) step-down DC-DC converter, which has achieved 20W. Since it can correspond from ultra low output voltage of 0.8V, it can be used for the latest DSP, ASIC applications. High efficiency by synchronous rectification system, ultra high-speed responding, saving space by no external components, and by having SIP, DIP, SMD packages etc. this has achieved a product that has exceeded our conventional common sense.

<Features>

- High-speed responding
- Efficiency 93%
- ON/OFF Control
- Adjustable Output
- The Latest Power-IC adopted
- The Latest Technology, Synchronous Rectification Circuit
- Additional external capacitor not required
- Short-Circuit, Over-Current Protection
- Non-Isolated Type Converter
- Amazing Minimum Size
- Operating Temp. -40°C to +85°C
- Heat Sink not required
- High Reliability, High Performance
- RoHS Compliance



<Model, Rating>

Table 1

Model	Rating Input Voltage Vdc	Input Voltage Range Vdc-Vdc	Output Voltage Vdc	Output Current A	Non-Load Current mA(typ.)	Ripple & Noise mVpp(typ.)	Efficiency %(typ.)	Package type
BSV-3.3S6R0A	5.0	3.0-5.5 (*1)	3.3(0.8-3.6)	6	65	40	93	SIP
BSV-3.3S6R0DA								DIP
BSV-3.3S6R0SA								SMD

(*1) Input Voltage should be 0.5V or more higher than output voltage.

<Specification>

Table 2

Rating Input V/ Range	Refer to Table 1
Rating Output V	When Vadj pin is open, output voltage will be set at 3.3V. (The accuracy of output V setting is ±3% max.)
Adjustable Output V Range	Output Voltage is adjustable according to the range above.
Line Regulation	1.5%typ. 3.0%max. (For the regulation of input voltage range 3.8-5.5V)
Load Regulation	2.0%typ. 4.0%max. (For 0-6A of load regulation, at rating input.)
Temp. Regulation	±0.02%/°C typ. (For the change of operating temp. -10°C to +50°C)
Ripple & Noise	100mVpp max. (Rating input, rating output, room temp.) (20MHz bandwidth)
Efficiency	93% (Rating input/ output, room temp., refer to Table 1)
Over-Current Protection	Operates at 105% or more rating load current, auto recovery type. Avoid long time short-circuit condition.
Over-Voltage Protection	None
Standby Current	1mA typ.
Remote ON/OFF	Between ON/OFF (1pin) - S.GND (5-8pin) Open: Output ON, Short: Output OFF (Refer to application)
Remote Sensing	The voltage between converter's output pin [9-11pin] -GND pin [5-8pin] and sensing voltage [voltage between 14-15pin] difference is 10% (0.1V-0.3V) or below of the sensing voltage.
P-Good Signal	At normal output: Open (H), at output drop: Short (L), open drain output 5mA max. * No P-Good function for BSV-3.3S6R0A (SIP type)
Operating Temp. Range	-40°C to +85°C (Refer to the thermal derating graph.)
Storage Temp. Range	-40°C to +85°C
Humidity Range	20%-95%R.Hmax. (Max. Wet-bulb Temp. 35°C, non-condensing)
Storage Condition	For the converter before being mounted, store at 30°C/ 60% R.H. or below.
Cooling Condition	Refer to the thermal derating graph
Vibration	5-10Hz All amplitude 10mm, 10-55Hz acceleration 2G (1hour in each of 3 orthogonal axes)
Shock	Acceleration 20G (3times in each of 3 orthogonal axes), Shocking time 11±5ms
Weight	4g typ.
Outline	SIP type W=24 L=33 H=5.0 typ. (mm) (For dimensions refer to outline.) DIP type W=22.25 L=33 H=6.0 typ. (mm) (For dimensions refer to outline.) SMD type W=23.9 L=33 H=6.0 typ. (mm) (For dimensions refer to outline.)

* The above specification will be provided with rating value, unless specified condition is described.

Bellnix DC-DC CONVERTERS

BDD20080825

<Outline>

1. BSV-3.3S6R0A (SIP type)

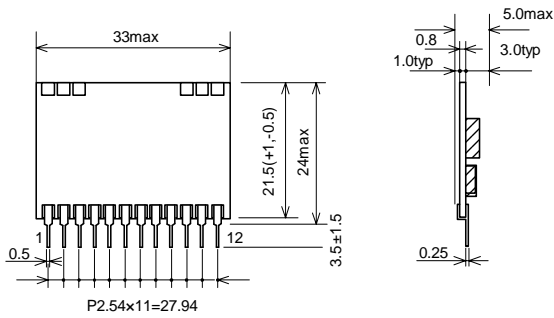

Figure 1

- Dimensions: mm
 - Tolerance when nothing specified ±0.5

Table 3

Pin	Function
1	on/off
2	Vin
3	Vin
4	Vin
5	GND
6	GND
7	GND
8	GND
9	Vout
10	Vout
11	Vout
12	V.ADJ

2. BSV-3.3S6R0DA (DIP type)

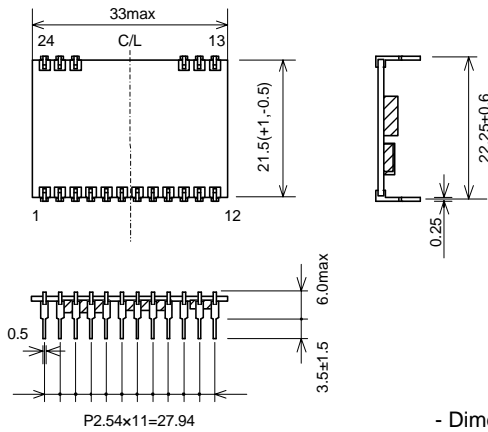

Figure 2

- Dimensions: mm
 - Tolerance when nothing specified ±0.5

Table 4

Pin	Function	Pin	Function
1	on/off	11	Vout
2	Vin	12	V.ADJ
3	Vin	13	NC
4	Vin	14	+S
5	GND	15	-S
6	GND	22	NC
7	GND	23	P-Good
8	GND	24	NC
9	Vout		
10	Vout		

3. BSV-3.3S6R0SA (SMD type)

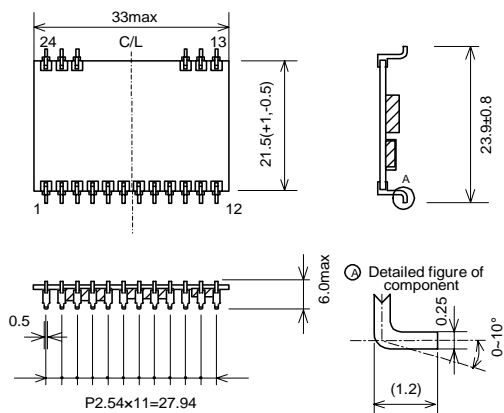

Figure 3

- Dimensions: mm
 - Tolerance when nothing specified ±0.5

Table 5

Pin	Function	Pin	Function
1	on/off	11	Vout
2	Vin	12	V.ADJ
3	Vin	13	NC
4	Vin	14	+S
5	GND	15	-S
6	GND	22	NC
7	GND	23	P-Good
8	GND	24	NC
8	GND		
9	Vout		
10	Vout		

Ultra High Efficiency 93%
High-speed Response, Step-Down DC-DC Converter

Bellnix[®]

20 Watt BSV-A Series

<Block Diagram>

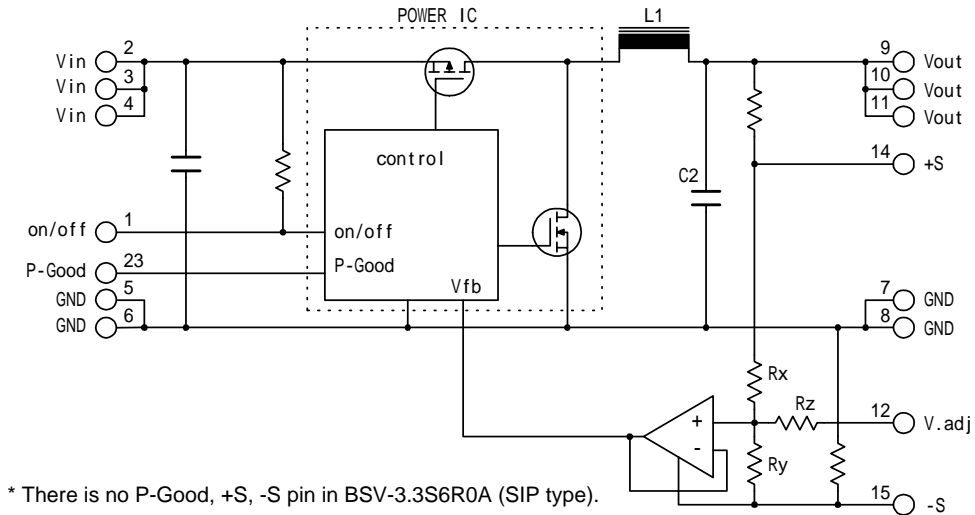

Figure 4

<Thermal Derating>

Please set this product in the place where good convection is ensured.

And when using this product in the environment that ambient temp. is 40°C or more, please refer to the thermal derating below.

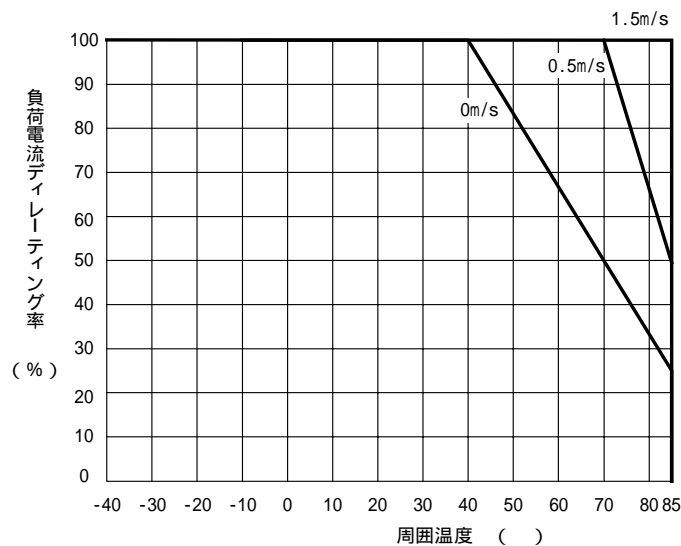

Figure 5

Ultra High Efficiency 93% High-speed Response, Step-Down DC-DC Converter

Bellnix

20 Watt BSV-A Series

<Standard Connection Circuit Diagram>

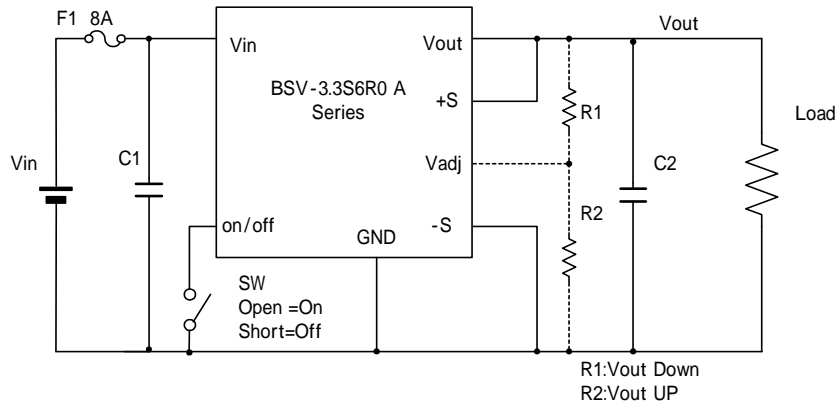

* There is no P-Good, +S, -S pin in BSV-3.3S6R0A (S1P type).

Figure 6

Note 1: When not using the ON/OFF control, keep ON/OFF pin open.

Note 2: When not adjusting output, keep V.ADJ pin open.

Note 3: When it includes inductance in input line or switching element is connected to the input side or the wire is long, fulfilling the performance C1 will be required. Also we recommend a pattern with an additional C1 to lower the input impedance, and to verify on a actual equipment. Or, by adding C2 you can lower the output ripple more.

Recommended Capacitor

C1=33μF10WV

C2=2.2μF-22μF

C2: An output capacitor is built-in, so it is not required. However, by connecting 2.2μF-22μF, you can lower the noise more.

Note 4: There is no +S, -Spin in BSV-3.3S6R0A (S1P type).

<Method of Adjusting Output Voltage>

When using at 3.3V without adjusting output voltage, keep V.ADJ pin (12Pin) open.

By connecting a resistor between +Vout pin (9-11Pin) and V.ADJ pin (12Pin), you can adjust the output voltage within the range of 0.8-3.3V. (Vout Down Control)

By connecting a resistor between Vadj pin (12Pin) and GND pin (5-8Pin), you can adjust the output voltage within the range of 3.3V-3.6V. (Vout Up Control)

To calculate the external resistance, please refer to the equation below. After calculating the external resistance, please check the output voltage and adjust the resistance value.

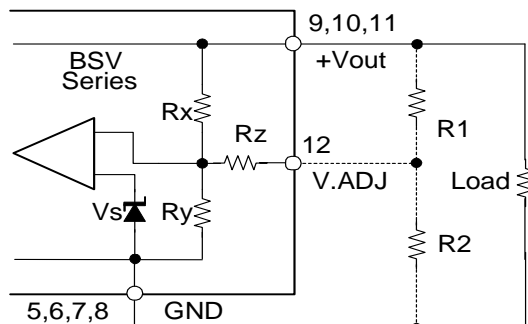

Figure 7

To set within the range of 0.8V-3.3V

$$R1 = \frac{Rx \cdot Ry (Vo - Vs)}{Rx \cdot Vs - Ry (Vo - Vs)} - Rz$$

To set within the range of 3.3V-3.6V

$$R2 = \frac{Rx \cdot Ry \cdot Vs}{Ry (Vo - Vs) - Rx \cdot Vs} - Rz$$

Vo= Required output V (Adjustable voltage range=0.8-3.6V)

Rx=10.2k ohm

Ry=2.7k ohm

Rz=0.1K ohm

Vs=0.703V

<ON/OFF Control>

- ON/OFF Function

By using this ON/OFF control function, ON/OFF control can be secured in the output without intermitting input.

This is an effective function when composing a power supply system sequence. And this can also be used as a power standby function for saving power control.

- Not using ON/OFF Function

Do not use the ON/OFF function, keep ON/OFF pin open.

- Method of ON/OFF Control

Between ON/OFF pin (1Pin) and S.GND (5-8Pin)

Open ---- Output=ON

Short ---- Output=OFF (0-0.7V 0.5mA typ.)

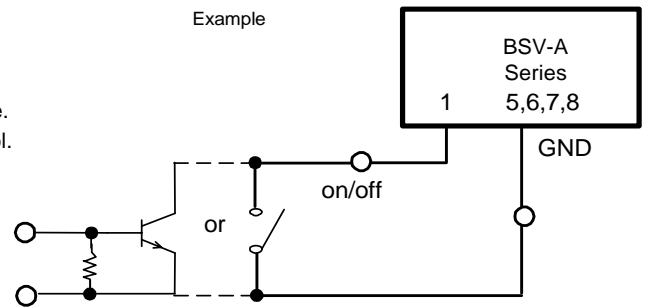

Figure 8

<To prevent reverse connection of Input Power Supply (ex.)>

This product is a non-isolated type DC-DC converter that steps-down from (+) to (+).

If you connect the input voltage reversed by mistake, it will be damaged. If there is a possibility of reverse connection, please add a protection as shown in the right figure.

The right figure is an example using fuse and diode.

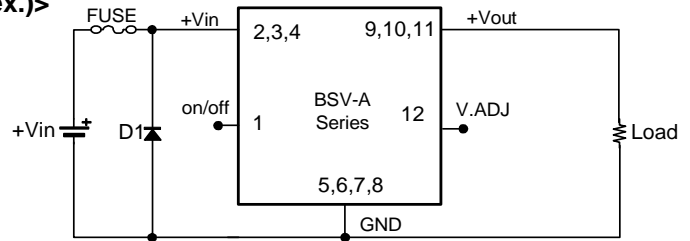

Figure 9

<Over-Voltage Protection (ex.)>

This product does not have a built-in over-voltage protection.

If the switching element in this converter is damaged in short mode input voltage (+Vin) will be as it is.

However, to prepare for damage at over-voltage mode, we recommend to add a circuit to intercept the supplying power circuit.

Note1: When it is damaged at over-voltage mode, ON/OFF control does not operate.

Note2: When there is a ON/OFF function on the supplying power side, this may be used.

Note 3: Be sure that the DC power supply on the supplying side has the capacity to fuse the fuse.

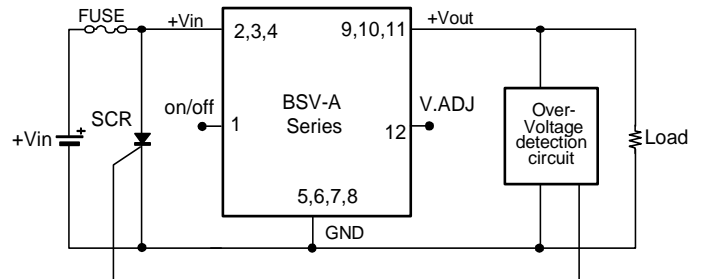

Figure 10

<Cleaning Conditions>

This product can not be washed whole. No-clean solder paste is recommend for this product.

Only for SIP type and DIP type, if cleaning is necessary, use IPA and handwash the soldered surface by brush cleaning.

And after cleaning, dry sufficiently before using this product.

<Soldering Conditions>

Solder under the following conditions.

1. With soldering iron 340°C to 360°C within 3sec.
2. With soldering dip 240°C to 260°C within 10sec.
3. Reflow method (only for SMD type)
 - Preheating Temp.: 150-180°C, within 1min.
 - Peak heating temp.: 250°Cmax.
 - Reflowing frequency: once

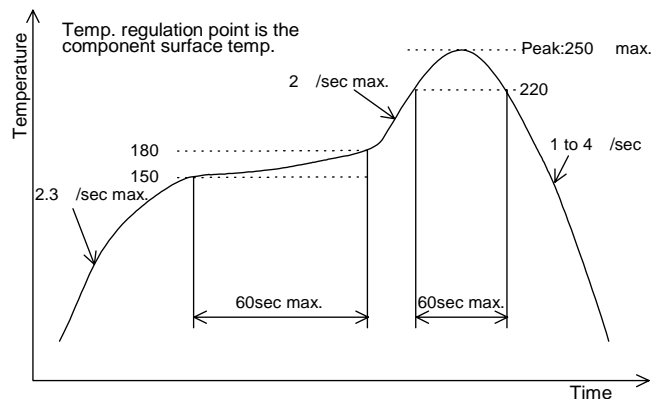

Figure 11

<Method to decrease the noise (ex.)>

Usually BSV-A series is used by adding an input/output capacitor, and to make the most of the converter's performance, and to lower the noise level further more, consider the following items when in designing the printed circuit board.

1. Use low impedance capacitor with good high frequency characteristic.
2. Shorten lead of each capacitor as much as possible, and make it low lead inductance.
3. Make the wiring loop space between the (+) and (-) of both input and output pin side as small as possible. The influence of leakage inductance can be decreased.
4. Design the print pattern of the main circuit as thick and short as possible.

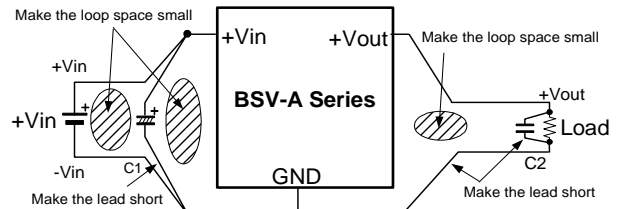

Figure 21

<Precautions>

- For this product parallel/ series operation is not possible.
- For mounting this product, please do not use connector or socket. The performance may not be fulfilled by the effect of contacting resistor. Mount to print board by soldering.
- This product has a built-in over-current and short protection circuit, but long time short circuit will cause failure, so please avoid it.
- May not be used for what would affect lives or properties directly by the failure of this product. Please confirm before adopting.
- Product can not be used under oscillation, strike or temp. condition that are out of the specification. Contact for any questions.
- There is possibility of damage from static. When the worker has electrified static, please earth discharge and working on an earthed worktable will be recommended.
- This product does not have a built-in fuse. When it is abnormal, please connect the fuse with +input line as a protection for excessive current flowing into the input. Please give capacity, so that the fuse can be cut to from the power supply.
- This product does not have a built-in over-voltage protection. When over-voltage is abnormally generated in the module, there is such a mode that the input voltage appears to the output straight, and which may cause smoke and ignition. Please make sure to add the over-voltage protection circuit to prevent it.
- No test certificate is attached to this product.