

BSV-m3, m6, m8 is an ultra small size (15x24x4mm size) and light weight (2.6g) step-down DC-DC converter, which has achieved maximum 26W. Since it can correspond from ultra low output voltage of 1.0V, it can be used for the latest DSP, ASIC applications. Due to high-speed response, high efficiency by synchronous rectification circuit technology, saving space by no external components, an excellent performance beyond our common sense has been achieved.

<Features>

- Latest Power-IC adopted
- High-speed Response
- Efficiency 94%, 96%
- ON/OFF Control
- Heat Sink not required
- The Latest Technology, Synchronous Rectification Circuit
- Additional external capacitor not required
- Short-Circuit, Over-Current Protection
- Adjustable Output
- Non-Isolated Type Converter
- Ultra Minimum Size
- Operating Temp. -40°C to +85°C
- High Reliability, High Performance
- RoHs Compliance

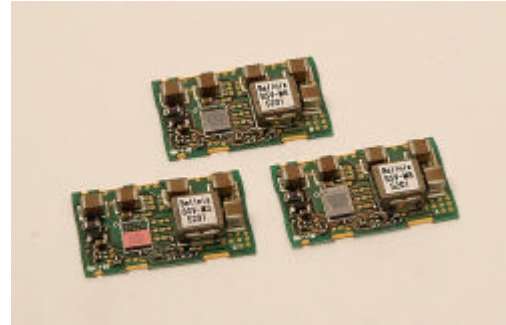

<Model, Rating>

Table 1

Model	Rating Input Voltage Vdc	Rating Output Voltage Vdc	Rating Output Current A	No-Load Input Current mA(typ.)	Ripple Noise mVpp(typ.)	Efficiency %(typ.)	Package Type
BSV-3.3S3R0M	5.0 (3.0-5.5)	3.3 (1.0-3.3)	3	30	30	96	SMD
BSV-3.3S6R0M			6	60	50	94	
BSV-3.3S8R0M			8	70	50	96	

Note 1: Rating input voltage () is the voltage range, and the input voltage needs to be 0.5V or more compared to the output voltage.

Note 2: Rating output voltage () is the adjustable range.

Table 2

<Specification>

	BSV-3.3S3R0M	BSV-3.3S6R0M	BSV-3.3S8R0M	Conditions
Input voltage/range	Refer to Table 1.			
Output voltage accuracy	+3.3V±3%			VAR pin open.
Line regulation	0.5% typ.			For the regulation of Vin=3-5.5
Load regulation	1.0% typ.			For the regulation of Iout=0A-rating
Temperature coefficient	±0.02%/ typ.			For the regulation of Ta=-40 to +50°C
Adjustable output range	1.0-3.3V			Refer to table 1
Ripple & Noise	30mVp-p typ.	50mVp-p typ.	50mVp-p typ.	BW=20MH z
Efficiency	96%typ.	94%typ.	96%typ.	
Over-Current Protection	Operates at 105% or more rating load, auto recovery type.			Avoid long-time short-circuit condition.
Over-Voltage Protection	None			Refer to page 3, adjusting voltage setting.
No Load Input Current	30mAtp.	60mAtp.	70mAtp.	Iout=0A
Remote on/off control	Between 5pin(RC) - 3pin(S.GND) [Open: Output ON, Short: Output OFF]			Refer to page 4, ON/OFF control.
UVLO start up voltage	2.8V typ.			
UVLO end voltage	2.7V typ.			
P-Good output	At normal output : H, At output dropping : L (0-0.4V Vin=+5V Sinks current=9mA or below)			Refer to page 4, power good output.
Operating temp. range	Operating Temp. -40°C to +85°C			Refer to page 6, temp. derating.
Storage temperature range	Storage Temp. -40 to +85°C (+125°C at baking)			
Humidity range	20%- 95%R.Hmax. (Ma. Wet-bulb temp. 35°C, non-condensing)			
Cooling condition	Refer to the thermal derating on page 6.			
Vibration	5-10Hz All amplitude 10mm (1 hour in each of 3 orthogonal axes), 10-55Hz acceleration 2G (1 hour in each of 3 orthogonal axes)			
Shock	Acceleration 20G (3 directions, 3 times each), Shocking time 11±5ms			
MTBF	1,000,000 Hrs			
Weight	2.6g typ.			Refer to the outline on page 2 for detail dimensions.
Outline	SMD type W=15 L=24 H=4.0 typ. (mm)			

* Unless otherwise specified, input and output is the rating value and ambient temperature is +25°C.

Ultra High Efficiency 94-96% High-Speed Response Step-Down DC-DC Converter BSV - m3,m6,m8



<Outline>

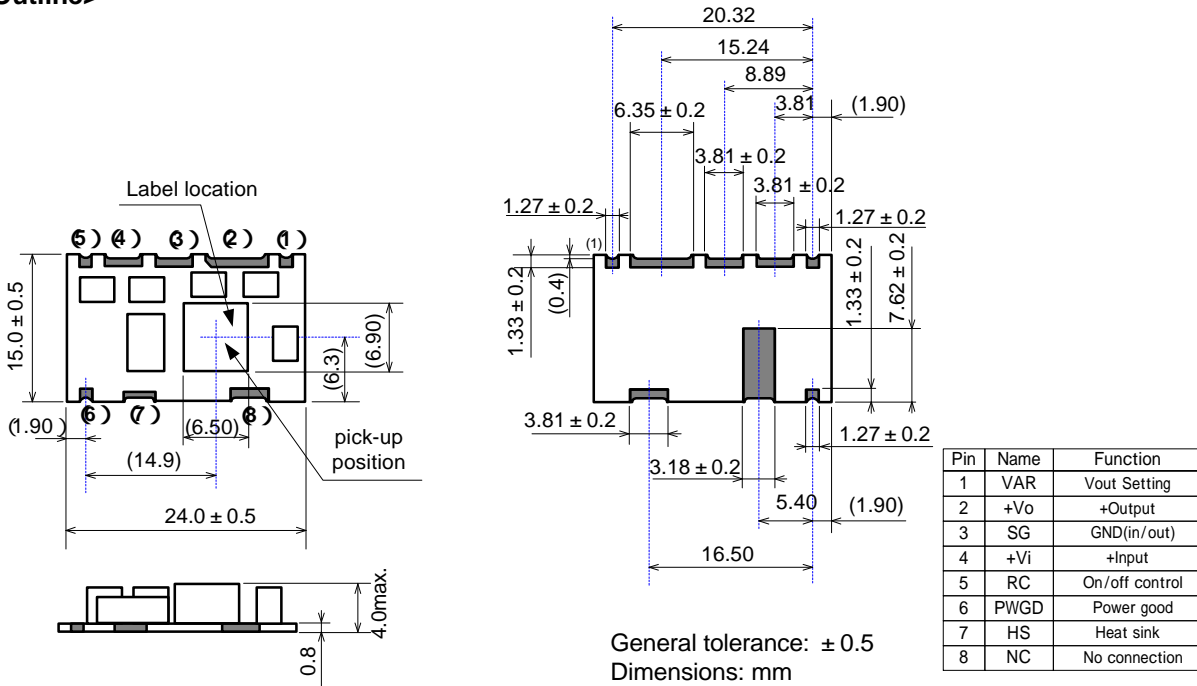
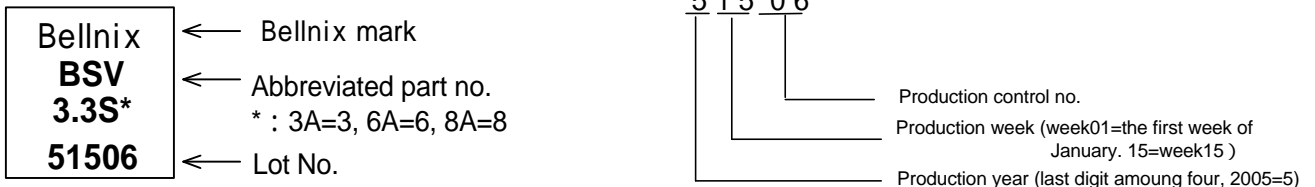

Figure 1

<Lot Number Display>



<Block Diagram>

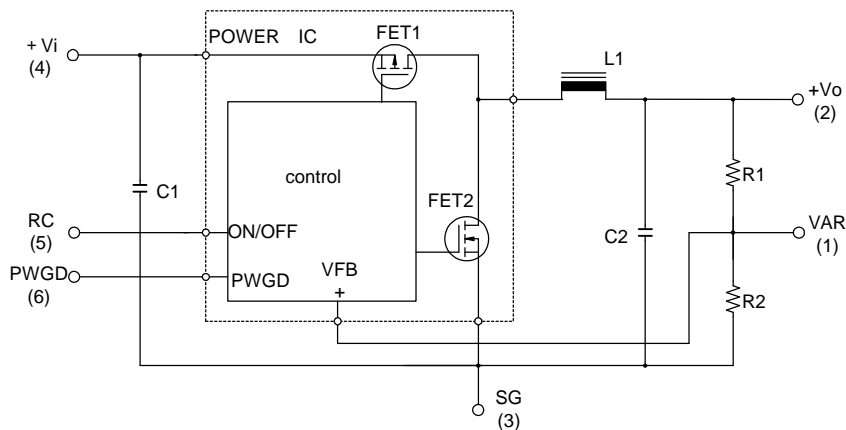

Figure 2

<Standard Connection Circuit Diagram>

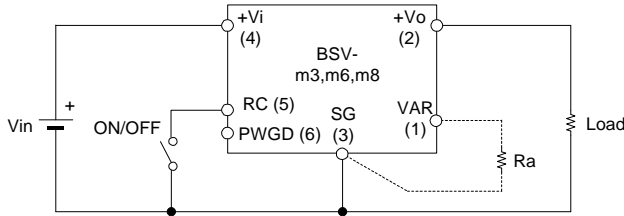

Figure 3 Standard Connection Circuit Diagram

< Outline >

Vout is 3.3V at Ra=open. When adjusting the output voltage to 3.3V or below, please connect Ra. When RC pin is connected to the SG pin, the converter will stop and when it is open, the converter will start operation. Keep RC pin open when not using the on/off control. Please refer to the other pages concerning other function such as adjusting the output voltage, remote ON/OFF etc.

- Notice: - For this converter, parallel operation of output is not possible.
 - Please make the wire distance between the input and the converter as short as possible.

<Input Capacitor>

Usually an input capacitor is not required, but adding an input capacitor (aluminum electrolytic capacitor) near the converter is recommended for the following case. Make the line impedance as small as possible between the input and the converter. The stability of the converter may become low if the input line impedance is large. Especially for a high speed regulation of load current application and also when the input line impedance is large, the converter's operation stability may become low. In such a case, please add an input capacitor Ci (several μF-several hundred μF).

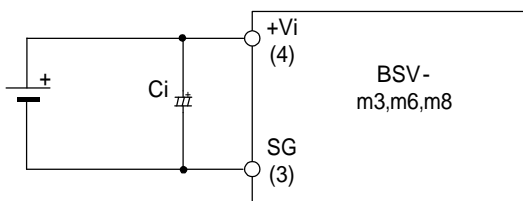

Figure 4 Adding an Input Capacitor

[Detail explanation]

When the load of the converter changes at high speed or because the input current increases rapidly at the converter's start-up, the voltage drop caused by line impedance will occur and a dip will occur in the input voltage. Especially in the case of using this converter at around 3Vin, since there is not much room until the UVLO stop voltage, a large input voltage dip will occur and hang to the UVLO stop voltage and cause an instant cut out of the converter's output.

An additional capacitor such as an aluminum electrolytic capacitor will be useful to avoid this.

<Output Capacitor>

No need to add an external capacitor to the output. However, please set the ceramic capacitor for high frequency decoupling necessary for the load circuit and device, very close to the load circuit and device. This converter responds with high-speed to the load current regulation, so there is a possibility to cut down the number of large capacitance decoupling capacitors, which is for load circuit, required for standard power supplies. However, the response capability for load regulation gets influenced by the output line impedance and the consumed current regulation speed of the load side is difficult to measure accurately. So be sure to cut down the number of large capacitance decoupling capacitors after careful testing under condition of actual circuit, components arrangement and operation. In this case, the number of the number of ceramic capacitors specified by load circuit and devices can not be cut down. So be sure to install the high frequency decoupling ceramic capacitors according to the load circuit and device instructions. A load capacitor with total capacity 500μF or below is recommended.

<Adjusting Output Voltage>

When setting the Vout to 3.3V or below, calculate Ra of the standard connection circuit diagram using the equation below and then connect.

And also, locate the Ra and Rb very close to the converter and make the wire as short as possible.

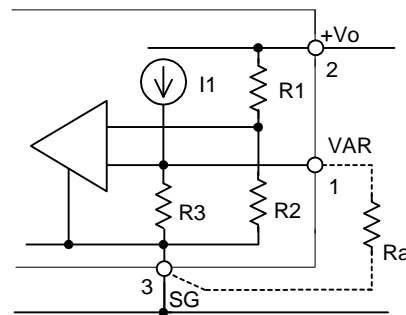

Figure 5 Connection when adjusting the output
Table 3

Trim Range Vo[V]	Ra[k ohm]
+1.0	37.60
+1.5	72.00
+1.8	103.61
+2.5	268.87
+3.3	Open

- Ra is calculated as follow

$$Ra = R2 \times R3 \times Vo / \{ (R1 + R2) \times R3 \times I1 - R2 \times Vo \} \text{ [ohm]}$$

In this equation, Vo[V] = desired output voltage.

$$R1 = 100\text{ohm}, R2=300\text{ohm}, R3 = 86.7\text{Kohm}, I1 = 0.0286\text{mA}$$

When it can not be set with one resistance, set it with multiple resistances in series. Ex.) 37.60K (36Kohm + 1.6Kohm)

<Remote ON/OFF Control>

- ON/ OFF Function
By using this ON/ OFF control function, ON/ OFF control can be secured in the output when intermitting input. This is an effective function when in composing a power supply system sequence. And this can also be used as a power standby function for saving power control.

- Not using ON/ OFF Function
When not using ON/OFF function, keep RC pin open.

- Method of ON/ OFF Control
Between RC (5pin) and SG (3pin)
Open ---- Output=ON
Short ---- Output=OFF (0-0.7V, 150μA typ.)

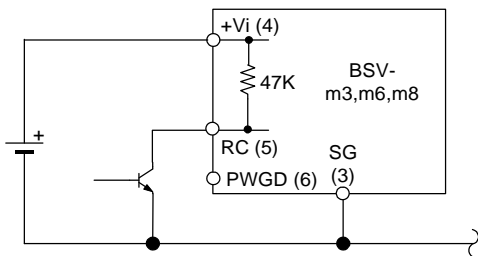

Figure 6 Remote ON/OFF Control

<Power Good Output>

Following is the explanation of power good output (PWGD) pin.
When the output voltage is normal output voltage - set voltage 0.3V typ., the open drain switch will become open. When the output voltage drops, the internal open drain switch will be grounded to SG.

PWGD pin is internally pulled up by the 47k ohm resistance connected to the +Vin pin. When the input voltage is minimum or below, the internal open drain switch may become off (open). And when the difference between input and output $V_{in}-V_{out}$ is 0.5V or below, even if the output voltage is normal it may become Low.

- PWGD (6pin) pin
At normal output High
At low output Low (0-0.4V, $V_{in}=+5V$, sink current 9mA or below)

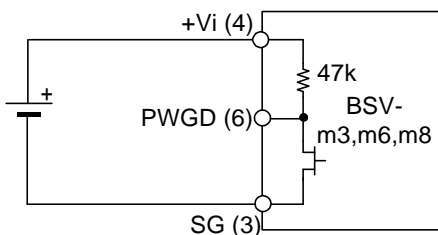

Figure 7 Power Good

<Input Undervoltage lockout>

To avoid malfunction when input power voltage decreases, this converter is equipped with an input undervoltage lockout (UVLO) function to stop the output at input power undervoltage.

When the impedance of input line is big, tolerance may occur when startup and turn off of the converter, however this will not effect the converter to be damaged. To avoid tolerance, it is required to cut down the voltage decrease (transitional and regular voltage decrease) due to impedance of input line as much as possible.

<Over-current protection circuit>

This circuit operates at rating 105% or more. When the over-current condition is dissolved, the converter will go back to usual rating voltage operation. Please avoid long time over-current or short load condition, which will cause thermal breakdown of the internal elements of the converter. The temperature measurement point (upper surface of the IC case) can not exceed 110°C.

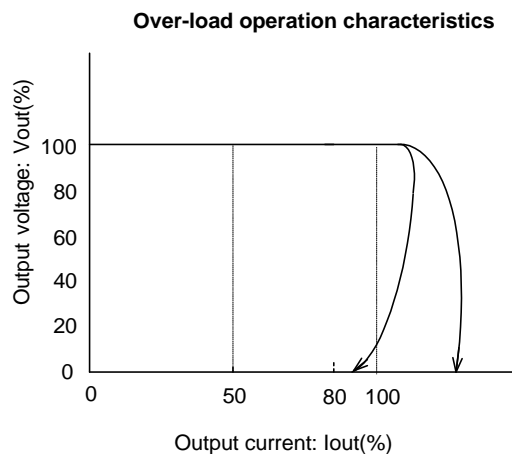

Figure 8 Over-Current Characteristics

Note
- For this converter's over-current protection, fold-back type may occur.

Ultra High Efficiency 94-96% High-Speed Response Step-Down DC-DC Converter BSV - m3,m6,m8



<Mounting>

- Recommended foot print

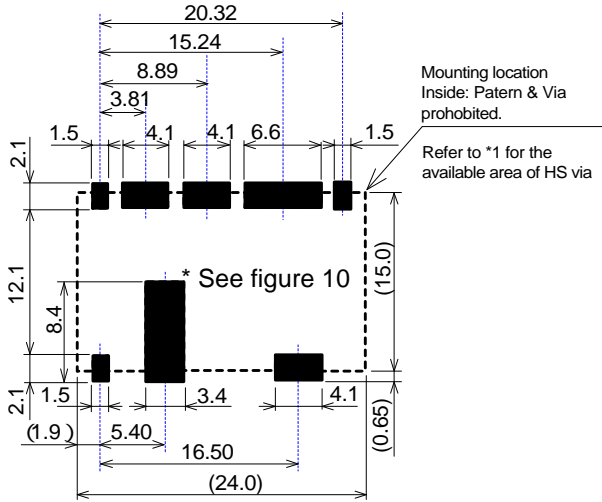

Figure 9

Wiring to the mother board surface layer is prohibited

*1 : As for making via to the HS (Heat Spreader) footprint, be sure to make it in the following location.

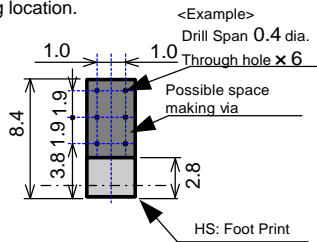

Figure 10

- Precaution for peripheral pattern

Wiring and via hole is prohibited on the motherboard surface layer which is right under the converter (Motherboard surface beta pattern as a noise shield is not required, since there is a built-in noise shield).

Make the pattern as thick as possible, since a large amount of current will flow into the wiring between the converter I/O and SG.

Be sure to form the number of via which has considered the output current value when connecting the I/O, SG pin to the power, GND beta layer with via. It is possible to wire the inside layer right under the converter, however please avoid to wire high-precision analogue and high-speed digital, which are sensitive to noise.

- Usage of HS (Heat Spreader)

The radiation level can be improved by via connection of HS to the internal beta pattern.

In case of wiring HS with beta pattern and via, be sure to form the via within the space shown in figure 9.

It is electrically isolated between HS and inside converter.

<Soldering Conditions>

- This converter is for reflow soldering and reflow is possible up to two times.

- Do not vibrate at reflow.

- Before reflow soldering the converters which have been left in the opened dry package, be sure to pre-bake (125°C±5°C, 12H) the converters. Re-baking will also be required before reflow soldering under the following conditions.

In dry-pack : More than 1 year

Dry-package opened : Kept in 30°C/60%RH for more than 168hours.

- It is not possible to flow soldering this converter.

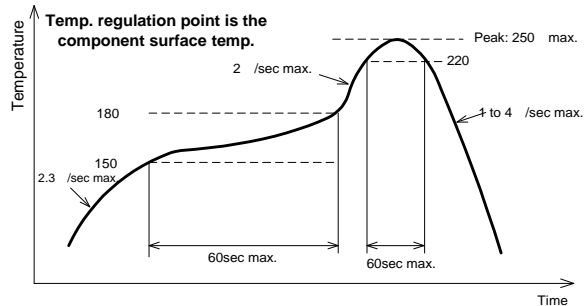

Figure 11 Recommended temperature profile

Storage this unit in the ambient temperature under 30°C and humidity condition under 60%RH.

And also obey the following notes.

- Keep it in a place where the unit will not be influenced by poisonous gas.
- Keep it in a place where the unit will not be exposed in an atmosphere of corrosion.
- Please avoid the dust.
- Keep it in a place where direct sunlight will not effect it.

Ultra High Efficiency 94-96% High-Speed Response Step-Down DC-DC Converter BSV - m3,m6,m8



<Rating temperature & thermal derating>

This converter operates in a wide temperature range, but when the ambient temperature is high, suitable radiation is required for cooling down. The following thermal derating is for proper use and assistance of thermal designing of this converter. To secure cooling, measuring temperature under the condition that the converter is mounted inside the device, system and at max. ambient temperature with min. air cooling is required. At this time, IC surface temperature should not exceed 100°C.

Radiation Pattern Conditions

- Board Material: FR-4, t1.6, two-layer printed board

- Size: 120×120, 35μ

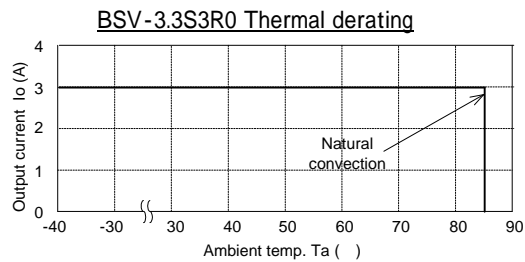

Figure 12

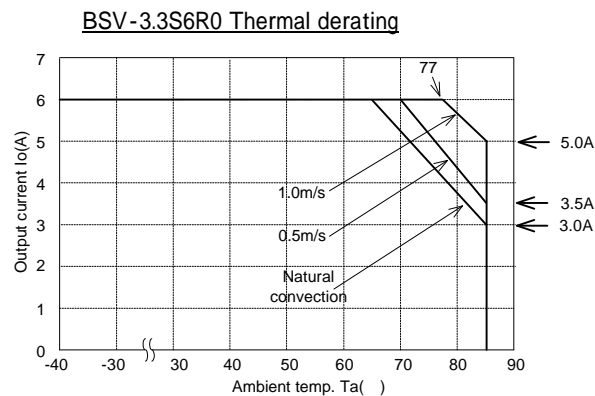

Figure 13

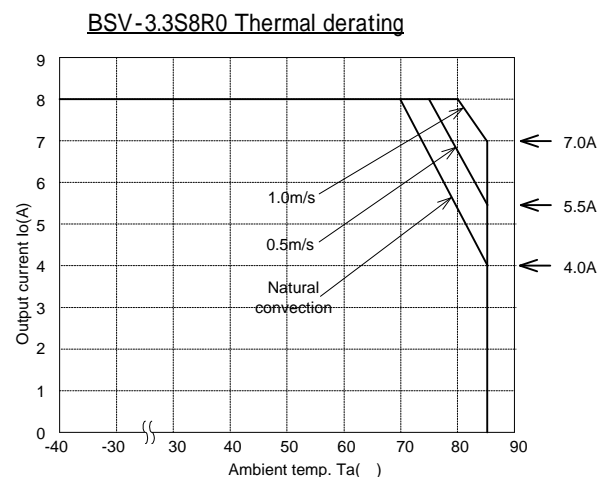

Figure 14

<To prevent reverse connection of Input Power Supply (ex.)>

This product is a non-isolated type DC-DC converter that steps-down from (+) to (+). If the input voltage is connected in reverse by mistake, it will be damaged. If there is a possibility of reverse connection, please add a protection circuit as shown in the figure below.

The figure below is an example using fuse and diode.

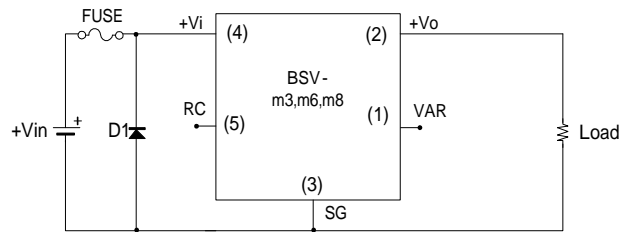

Figure 15

<Over-Voltage Protection (ex.)>

This product does not have a built-in over-voltage protection.

If the switching element in this converter is damaged in short mode, input voltage (+Vin) will go out as it is.

However, to avoid damage at over-voltage mode, in advance adding a circuit to intercept the supplying power circuit is recommended.

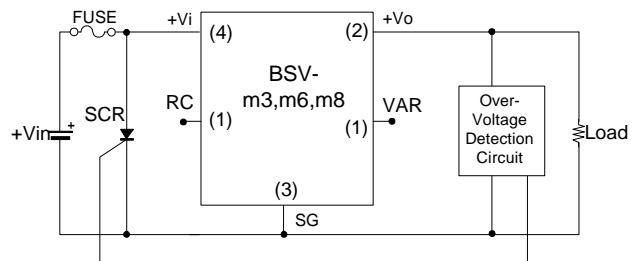

Figure 16

Note 1: When it is damaged at over-voltage mode, ON/OFF control does not operate.

Note 2: The ON/OFF function on the supplying power side can be used.

Note 3: Make sure that the DC power supply on the supplying side has the capacity to fuse the fuse.

<Cleaning Conditions>

This product can not be washed whole. No-clean solder paste is recommended for this product.

Ultra High Efficiency 94-96% High-Speed Response Step-Down DC-DC Converter BSV - m3,m6,m8



<Characteristics Data>

The following data is a standard at room temperature ($T_a=25^{\circ}\text{C}$).

Output Ripple & Noise Wave

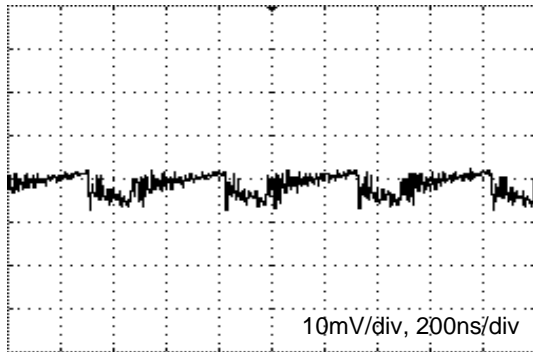

($V_{in}=5\text{V}$, $V_{out}=3.3\text{V}$, $I_{out}=3\text{A}$)

Figure 17 BSV-3.3S3R0M

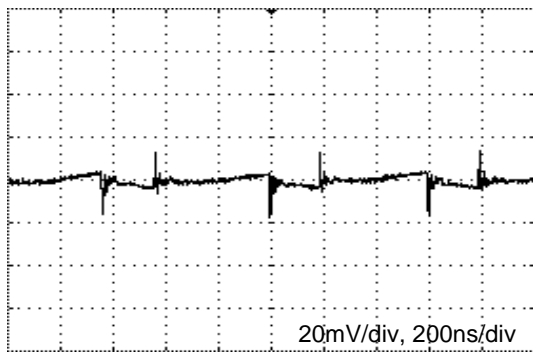

($V_{in}=5\text{V}$, $V_{out}=3.3\text{V}$, $I_{out}=6\text{A}$)

Figure 18 BSV-3.3S6R0M

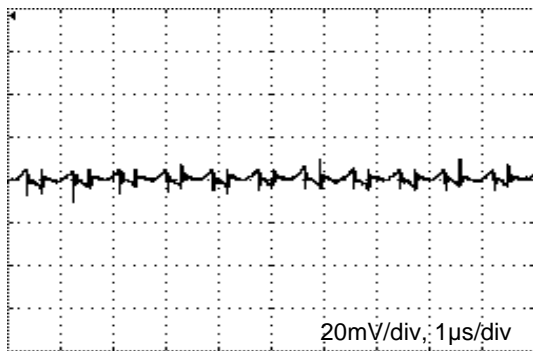

($V_{in}=5\text{V}$, $V_{out}=3.3\text{V}$, $I_{out}=8\text{A}$)

Figure 19 BSV-3.3S8R0M

Output voltage - Input voltage characteristics

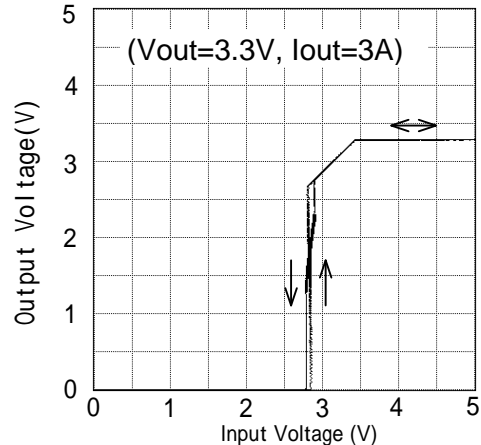

Figure 20 BSV-3.3S3R0M

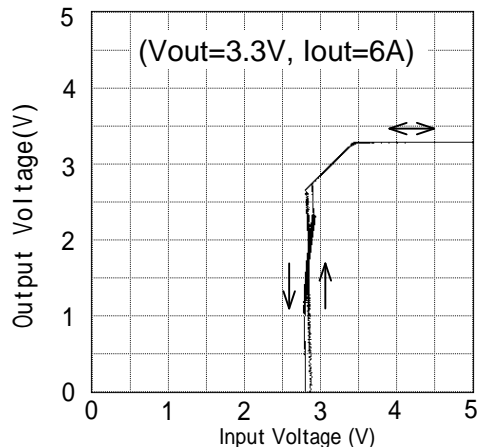

Figure 21 BSV-3.3S6R0M

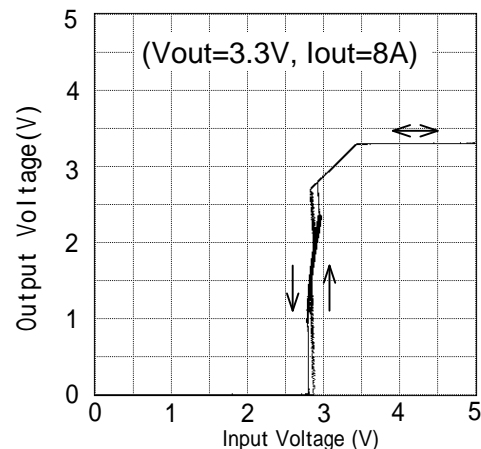

Figure 22 BSV-3.3S8R0M

Ultra High Efficiency 94-96% High-Speed Response Step-Down DC-DC Converter BSV - m3,m6,m8



<Characteristics Data>

The following data is a standard at room temperature ($T_a=25^\circ\text{C}$).

Input current - Input voltage characteristics

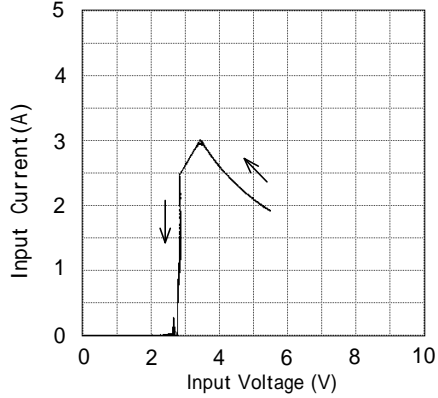

Input Current VS Input Voltage
($V_{out}=3.3\text{V}$, $I_{out}=3\text{A}$)

Figure 23 BSV-3.3S3R0M

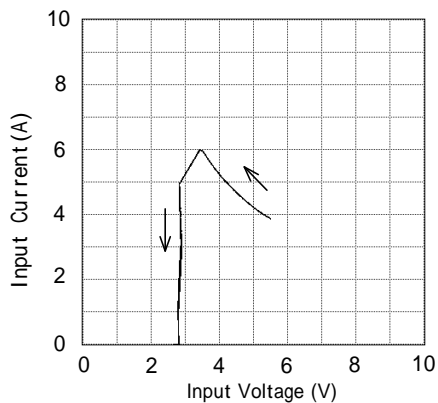

Input Current VS Input Voltage
($V_{out}=3.3\text{V}$, $I_{out}=6\text{A}$)

Figure 24 BSV-3.3S6R0M

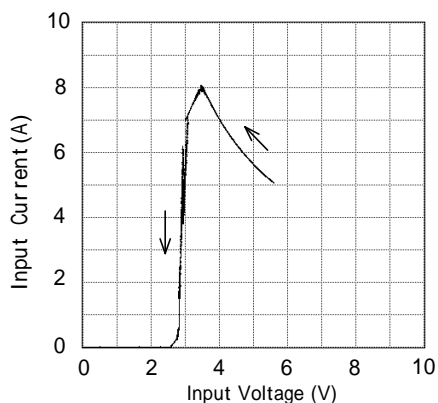

Input Current VS Input Voltage
($V_{out}=3.3\text{V}$, $I_{out}=8\text{A}$)

Figure 25 BSV-3.3S8R0M

Efficiency characteristics

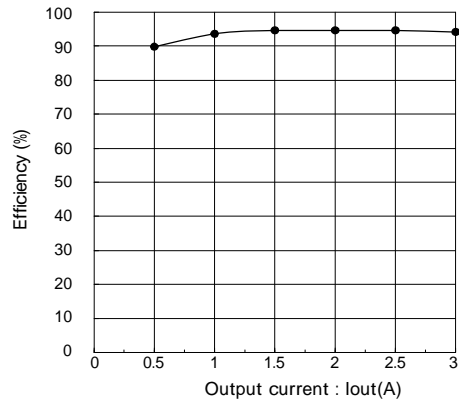

($V_{in}=5.0\text{V}$, $V_{out}=3.3\text{V}$)

Figure 26 BSV-3.3S3R0M

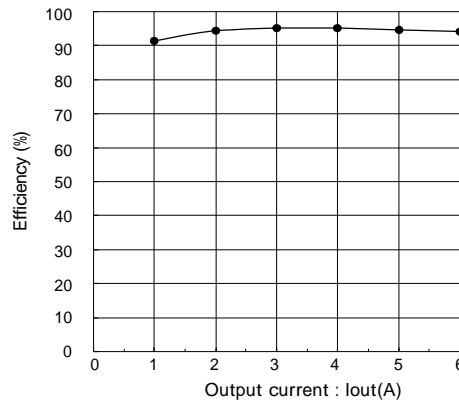

($V_{in}=5.0\text{V}$, $V_{out}=3.3\text{V}$)

Figure 27 BSV-3.3S6R0M

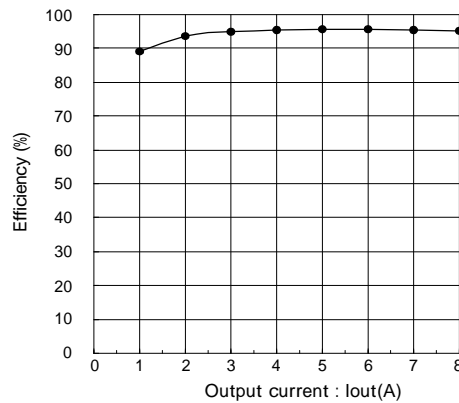

($V_{in}=5.0\text{V}$, $V_{out}=3.3\text{V}$)

Figure 28 BSV-3.3S8R0M

<Characteristics Data>

The following data is a standard at room temperature (Ta=25°C).

Internal loss characteristics

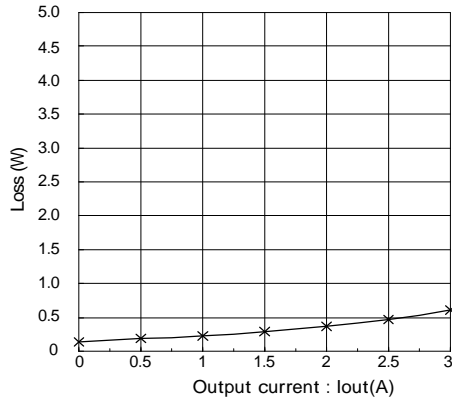

(Vin=5.0V, Vout=3.3V)

Figure 29 BSV-3.3S3R0M

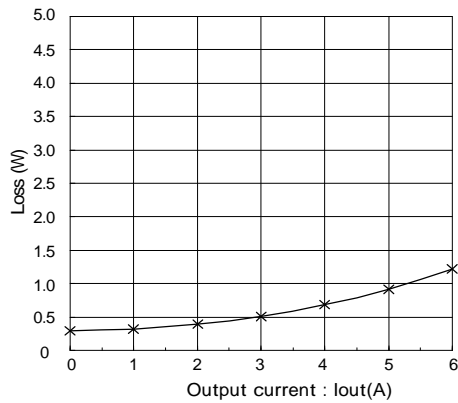

(Vin=5.0V, Vout=3.3V)

Figure 30 BSV-3.3S6R0M

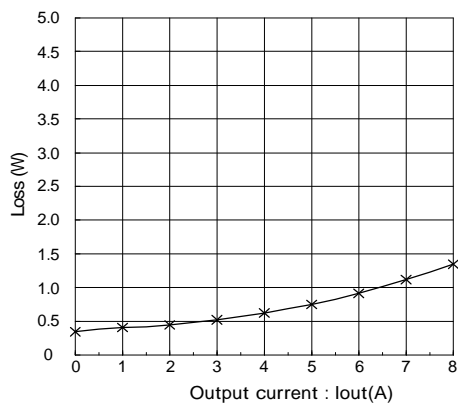

(Vin=5.0V, Vout=3.3V)

Figure 31 BSV-3.3S8R0M

Turn-on transient

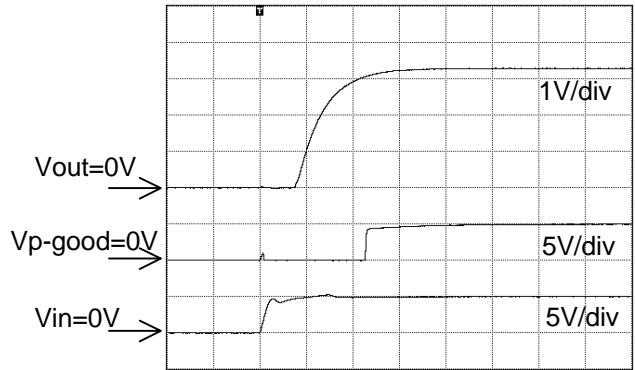

(Vin=5.0V, Vout=3.3V, Iout=3A)

Figure 32 BSV-3.3S3R0M

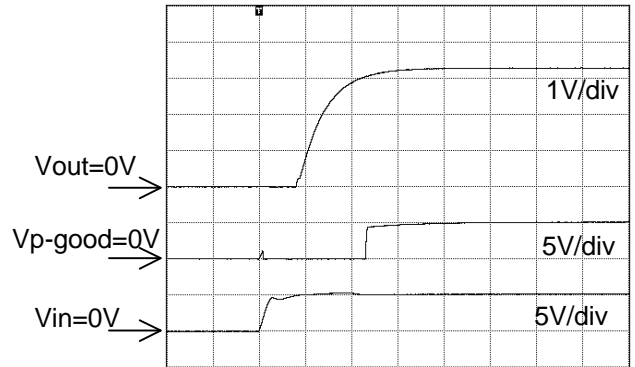

(Vin=5.0V, Vout=3.3V, Iout=6A)

Figure 33 BSV-3.3S6R0M

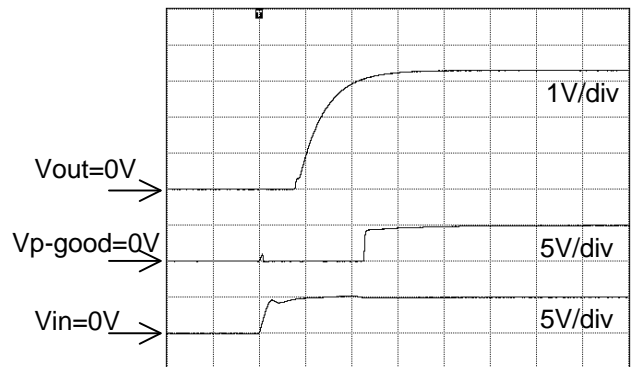

(Vin=5.0V, Vout=3.3V, Iout=8A)

Figure 34 BSV-3.3S8R0M

Ultra High Efficiency 94-96% High-Speed Response Step-Down DC-DC Converter BSV - m3,m6,m8



<Characteristics Data>

The following data is a standard at room temperature ($T_a=25^\circ\text{C}$).

Line regulation characteristics

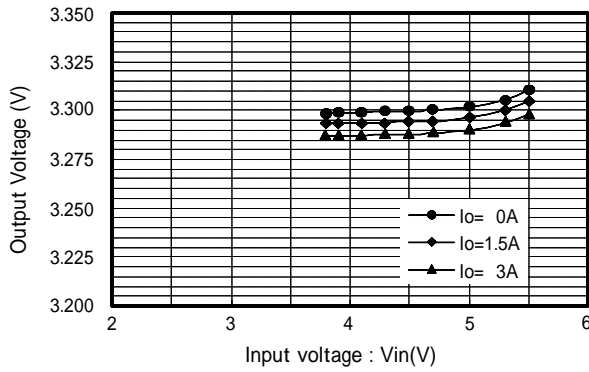

Figure 35 BSV-3.3S3R0M

Load regulation characteristics

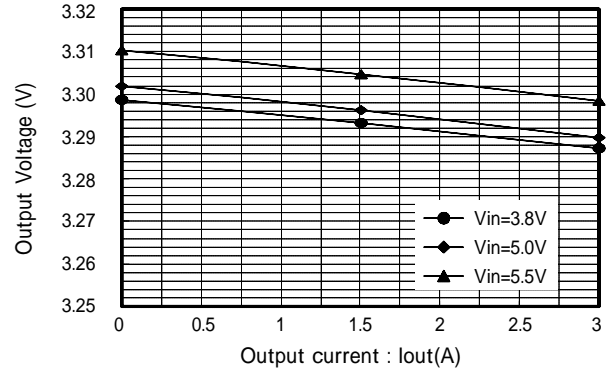

Figure 38 BSV-3.3S3R0M

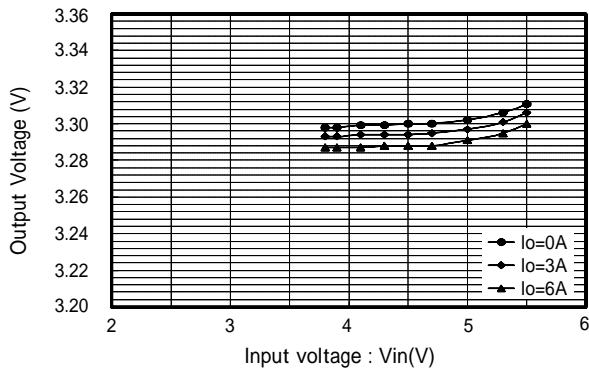

Figure 36 BSV-3.3S6R0M

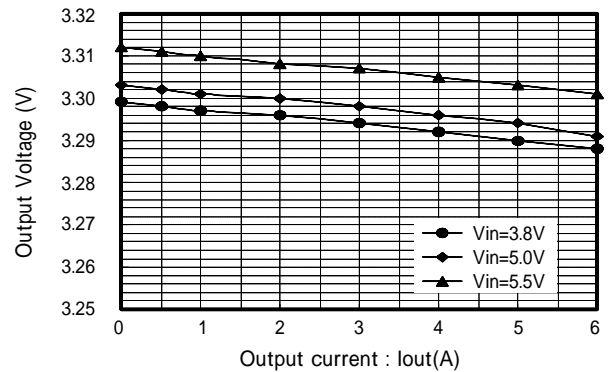

Figure 39 BSV-3.3S6R0M

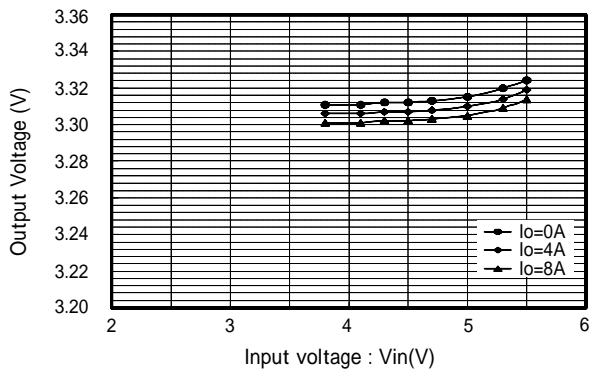

Figure 37 BSV-3.3S8R0M

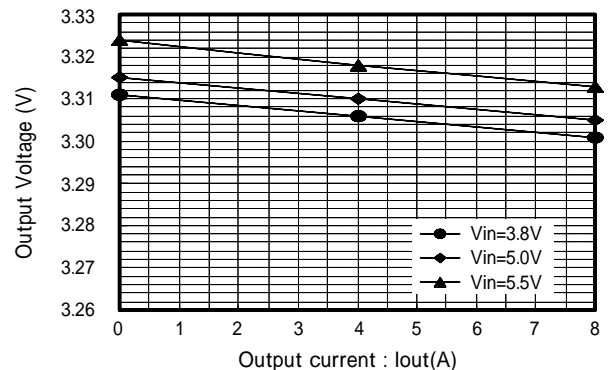

Figure 40 BSV-3.3S8R0M

Ultra High Efficiency 94-96% High-Speed Response Step-Down DC-DC Converter BSV - m3,m6,m8

Bellnix[®]

<Method to decrease the noise (ex.)>

Usually BSV-m3, m6, m8 are used by adding an input/output capacitor, and to make the most of the converter's performance and to lower the noise level further more, consider the following items when in designing the printed circuit board.

1. Use low impedance capacitor with good high frequency characteristic.
2. Shorten lead of each capacitor as much as possible, and make it low lead inductance.
3. Make the wiring loop space between the (+) and (-) of both input and output pin side as small as possible. The influence of leakage inductance can be decreased.
4. Design the print pattern of the main circuit as thick and short as possible.

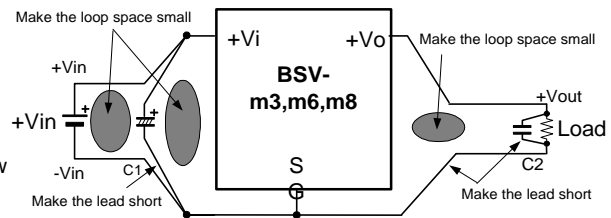

Figure 41

<Precautions>

- For mounting this product, please do not use connector or socket. The performance may not be fulfilled by the effect of contacting resistor. Mount to print board by soldering.
- This product has a built-in over current and short protection circuit, but long time short circuit will cause failure, so please avoid it.
- Please confirm before adopting, in case that it would affect lives or properties directly by the failure of this product, such as medical equipment, atomic control system and trains.
- Product can not be used under oscillation, strike or temp. condition that are out of the specification.
- There is a possibility of damage by static. When the worker has electrified static, please earth discharge and working on an earthed worktable will be recommended.
- This product does not have a built in fuse. When it is abnormal, please connect the fuse with + input line as a protection for excessive current flowing into the input. Please make sure that the power supply has the capacity that the fuse can be cut.
- This product does not have a built in over voltage protection. When over voltage is abnormally generated in the module, there is such a mode that the input voltage appears to the output straight, which may cause smoke and ignition. Please make sure to add the over-voltage protection circuit to prevent it.
- No test result certificate is attached to this product.

Bellnix[®]

Bellnix Co., Ltd.

5-7-8 Negishi Minami-ku Saitama-shi Saitama Japan 336-0024

TEL: +81-48-864-7733 FAX: +81-48-861-6402

E-mail: info@bellnix.co.jp

URL <http://www.bellnix.co.jp/>

All specifications are subject to change without notice.

PRINTED IN JAPAN BDD20050922-050901V2