

Ultra High Efficiency 93%

High-Speed Response, Step-Down DC-DC Converter

Bellnix[®]

BSV-H Series

BSV-H series is a small size (27.0x16.5x4.2mm size) and light weight (3.1g) step-down converter, which has achieved 39.6W. Since it can correspond from ultra low output voltage of 0.8V, it can be used for the latest DSP, ASIC applications. Due to high efficiency and high-speed response by synchronous rectification circuit technology, saving space by no external components, and with SMD package etc. an excellent performance beyond our common sense has been achieved.

<Features>

- Ultra Small Size 16.5x27mm
- Low Profile 4.2mm
- High-Speed Load Response
- Ultra High Efficiency
- Over-Current Protection
- External Capacitors not required
- Heat Sink not required
- RoHS Compliance
- Non-Isolated Type
- Under Voltage Lock Out
- Remote ON/ OFF Control
- Adjustable Output Voltage
- Surface Mount Package (SMD)
- Operating Temp. Range -40°C to +85°C (Temp. Derating required)



<Model/ Rating>

Table 1

Model	Rating Input Voltage	Input Voltage Range	Rating Output Voltage	Output Current	Output Voltage Adjustable Range	Ripple/ Noise	Efficiency	Package
	Vdc	Vdc	Vdc	A	Vdc	mVpp (typ)	% (typ)	type
BSV-3.3S12R0H	5.0	3.0-5.5	3.3	0-12	0.8-3.3	30	93	SMD

Note 1: The input and output voltage difference needs to be 0.5V or more. $V_{in}(V) - V_o(V) \geq 0.5V$

Note 2: Measurements of ripple noise is performed at BW=20MHz, with an additional multilayer ceramic capacitor of 47μF to the input and 4.7μF to the output.

Note 3: Depending on the ambient air temperature conditions, air flow is required.

<Specification>

Table 2

Rating Input Voltage/ Range	Refer to Table 1
Rating Output Voltage	+3.3V (Trim Pin at open)
Output Voltage Setting Accuracy	3.3V±3% (±0.099V)
Adjustable Output Voltage Range	Refer to Table 1
Line Regulation	0.5% typ. (Rating output, for the regulation of input voltage range 3.8-5.5V)
Load Regulation	1.0% typ. (Rating input/ output voltage, for the regulation of load 0-12A)
Temperature Coefficient	±0.02%/°C typ. (Input/ output rating, for the regulation of operating temp. range -40°C to +55°C)
Ripple & Noise	30mVp-p typ. (Input/ output rating, Bw=20MHz)
Efficiency	93% (Input/ output rating, ambient temp. 25°C ±5°C. Refer to table 1)
Turn-On Transient	0.3ms typ. (Resistance load)
Max. Output Capacitance	2200μF max.
Over-Current Protection	Operates at 105% or more rating load current, auto recovery type. Avoid long time short-circuit condition.
Over-Voltage Protection	None
Standby Current	1mA typ. (Vin=5V, short between ON/ OFF pin and GND pin.)
Remote On/ Off Control	Between 9pin (ON/ OFF) and 8pin (GND): output goes ON when in open, output goes OFF when in short (Refer to the ON/ OFF control paragraph)
P-Good Signal	At normal output: high, at output decrease: low, (Pull up to +Vin with a 10k ohm resistor inside)
Remote Sensing	Available
Operating Temp. Range	Operating temp. -40°C to +85°C (Refer to thermal derating graph)
Storage Temp. Range	Storage temp. -40°C to +85°C
Humidity Range	20%-95% R.H. max. (Max. wet-bulb temp. 35°C, non-condensing)
Storage Condition	For the converter before being mounted, store at 30°C/60% R.H. or below
Cooling Condition	Refer to thermal derating graph
Vibration	5-10Hz All amplitude 10mm, 10-55Hz acceleration 2G (1 hour in each of 3 orthogonal axes)
Shock	Acceleration 20G (3 directions, 3 times each), Shocking time 11±5ms
Weight	3.1g typ.
Outline	SMD type W=27.0 L=16.5 H=4.2 typ. (mm) (For detail dimensions refer to the outline on page 2)

* The above specification is provided with rating value, unless otherwise specified

<Adjusting Output Voltage>

When using at 3.3V without adjusting output voltage, keep Trim pin (7pin) open. By connecting a resistor between Trim pin (7pin) and -Sense pin, the output voltage can be adjusted within the range of 0.8-3.3V. (Connect -Sense pin to GND)

When adjusting the output voltage, place the Rx close to the converter and make the wiring of Rx as short as possible. If the Trim pin catches noise, malfunction may occur.

To calculate the external resistance, please refer to the equation below. After calculating the external resistance, please check the output voltage and adjust the resistance value.

To set within the range of 0.8V-3.3V

$$V_{out} = \frac{R1 + R2}{R2} \times \frac{R4 \times (R3 + Rx)}{R4 + (R3 + Rx)} \times I1$$

$$Rx = \frac{R2 \times R4 \times V_{out}}{(R1 + R2) \times R4 \times I1 - R2 \times V_{out}} - R3(ohm)$$

R1=100 ohm, R2=300 ohm, R3=22k ohm, R4=86.7k ohm, I1=0.0286mA, Vout=Requested output voltage (V)

(Be sure to adjust the units of resistor to ohm and current to A, when calculating.)

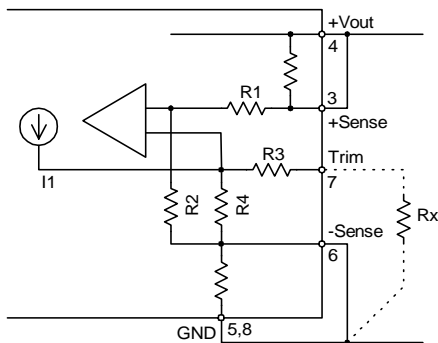

Ex.)

Desired Output Voltage Vout(V)	Rx (k ohm)
3.3	Open
2.5	246.7
2.0	110.7
1.8	81.6
1.5	50
1.2	27.4
1.0	15.6
0.8	5.7

<ON/ OFF Control>

- ON/ OFF Function

By using the ON/ OFF control function, ON/ OFF of the output without intermitting the input can be controlled. When not using the ON/ OFF function, keep the ON/ OFF pin open.

- Method of On/ OFF Control

Between ON/ OFF pin (9pin) and GND (8pin)

Open : Output=ON

Short (0-0.7V 1mA max.): Output=OFF

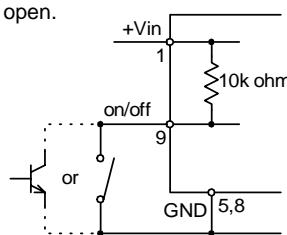

<P-Good Function>

By utilizing this P-Good pin, the output condition of the converter can be obtained. This pin is internally pulled up by the 10k ohm resistor connected to the +Vin pin.

It will be high at |Output voltage-Set voltage| 0.3V typ.

However, under the conditions written below, even if the output voltage is within this range, it may become low.

- When the input and output difference is Vin-Vout<0.5
- When the input voltage is below 3V
- When the output current is at over-current state.
- When the IC temperature is above 100°C

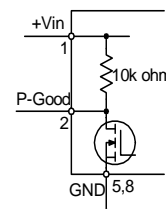

<Over-Voltage Protection Diagram (Ex.)>

This product does not have a built-in over-voltage protection. If the switching element in this converter is damaged in short mode, input voltage (+Vin) will go out as output. However, to avoid damage at over-voltage mode, in advance, adding a circuit to intercept the supplying power circuit can be recommended.

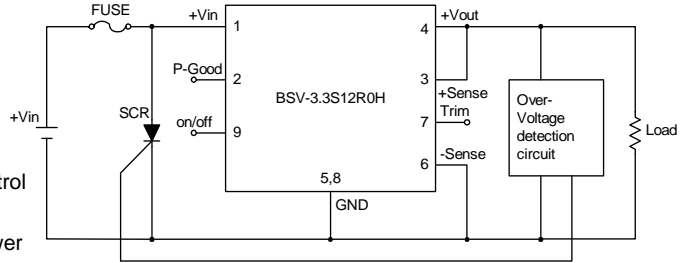

Note 1. When it is damaged at over-voltage mode, ON/ OFF control do not operate.

Note 2. When there is an ON/ OFF function on the supplying power side, this may be used.

Note 3. Be sure that the DC power supply on the supplying side has the capacity to fuse the fuse.

<To prevent reverse input voltage protection>

This product is a non-isolated type DC-DC converter that steps-down from (+) to (+). If the input voltage reversed is connected by mistake, it will be damaged.

If there is a possibility of reverse connection, please add a protection as shown in the right figure. The right figure is an example using fuse and diode.

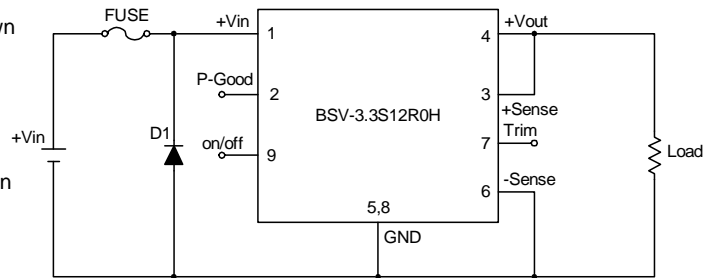

<Block Diagram>

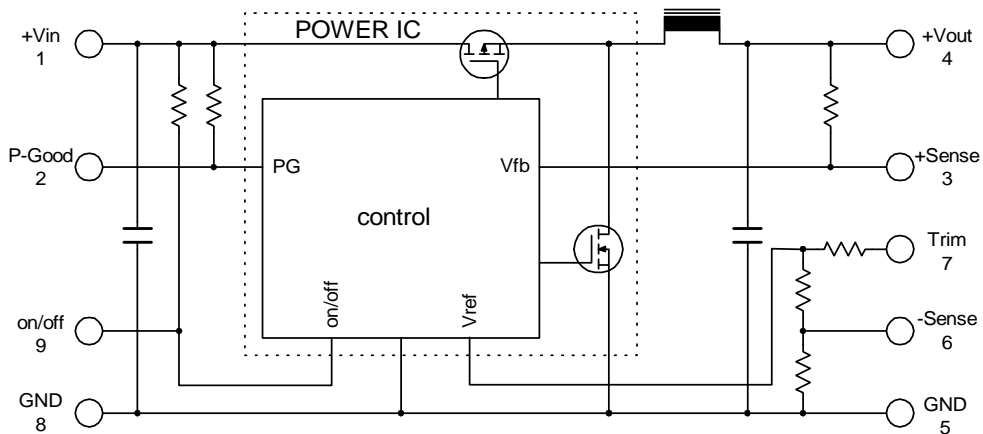

Ultra High Efficiency 93% High-Speed Response, Step-Down DC-DC Converter

Bellnix®

BSV-H Series

<Thermal Derating>

Set this product in a place where good convection is ensured. And also be sure to mount on a board, when using.

This product has been designed to radiate by utilizing the mounted board. So make the line to connect to the converter as wide as possible.

The radiation from GND is especially big, so make the GND line wide.

The derating curve below is a data when mounted on a double-side board of copper foil thickness 70μm, copper foil area 100×100mm (both sides) and thickness of the board 1.6mm. The radiation characteristics will change depending on the wiring, so please refer to the data.

The thermal characteristics for this converter will be largely influenced by the mounted board and the ambient condition. For this reason, finally mount the converter into the device that will be actually mounted. And when it is operated at the maximum ambient temperature of the equipment, be sure that the temperature of the board surface does not exceed 100°C.

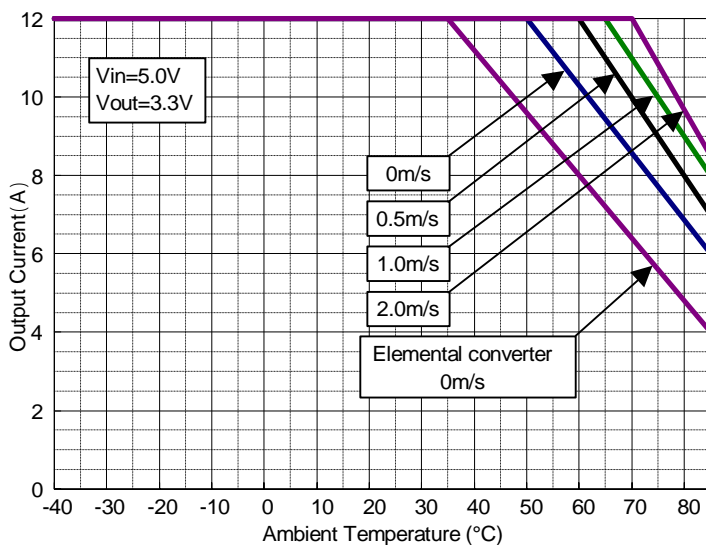

Pattern Conditions for heat radiation
 - Copper foil thickness 70μm
 - Copper foil area 100×100mm(both sides)
 - Board thickness 1.6mm

<Cleaning Conditions>

This product can not be washed whole. No-clean solder paste is recommended for this product.

<Soldering Conditions>

- Soldering Conditions

Solder under the following conditions.

Pre-heating temp.: 150-180°C, within 1min.

Peak heating temp.: 250°C max.

220°C or more, within 1min.

Reflow: twice

Note 1. Do not give shock at reflow.

Note 2. This converter can not be mounted by flow.

Note 3. This converter can not be reflowed with the component side faced down.

- About storage before being mounted

Storage conditions before being mounted should be 30°C/ 60% RH or below.

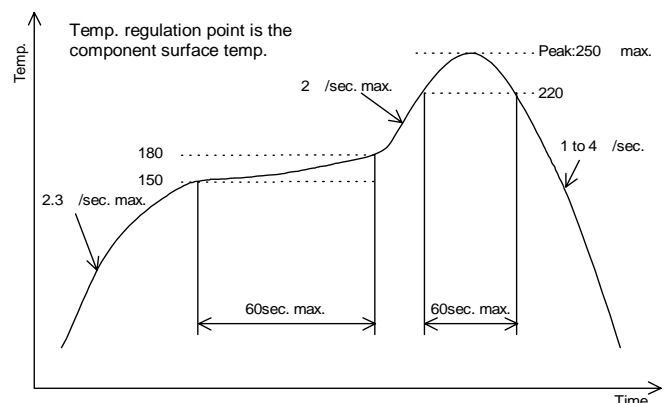

<Method to lower the noise (ex.)>

Usually BSV-H series is used, adding an input/ output capacitor, please make sure to design the printed board with special attention to the following items in order to obtain lower noise level by taking advantage of the performance of the converter.

1. Use low impedance capacitor with good high frequency characteristic.
2. Shorten the lead of each capacitor as much as possible, and make it low lead inductance.
3. Make the wiring loop space between the (+) and (-) of both input and output pin side as small as possible. You can decrease the possibilities of leakage inductance.
4. Design the printed pattern of the main circuit as thick and short as possible.

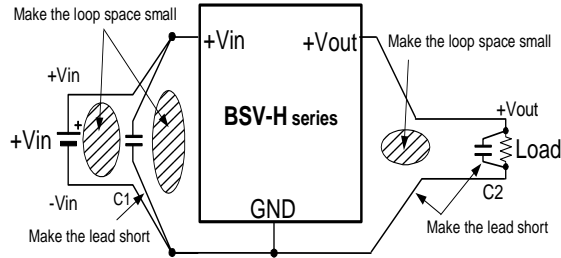

<Precautions>

- This product is for being used in general electric equipments (business equipments, telecommunication equipments and measurement equipments). Can not be used in medical equipments, nuclear equipments and trains which would affect lives or properties directly by the failure of this product. Be sure to contact our sales when using in besides general use.
- For this product parallel and series operation are not possible.
- For mounting this product, please do not use connector of socket. The performance may not be fulfilled due to the effect of contacting resistor. Mount to print board by soldering.
- This product has a built-in over-current, short protection, but long time short circuit will cause failure, so please avoid it.
- There is possibility of damage when used under electric conditions and environmental conditions such as temperature that are out of the standards. Be sure to be use within the standards.
- There is possibility of damage by static. When the worker has electrified static, electrical discharge should be done and the working on the table so grounded may be recommended.
- Do not store in a place where corridible gas may be generated or a dusty place.
- This product does not have a built-in fuse. Connect a fuse to the +input line for protection when over-current flows into input at abnormal. Please be sure that the supplying power has the capacity to fuse the fuse.
- This product does not have a built-in over-voltage protection. When over-voltage occurs due to the abnormality in the module, there is a mode that input voltage comes out at it is, and may cause smoke and ignition. To preven this, be sure to add over-voltage protection.
- No test result certificate attached to this product.