

BSV-H series is a small size(23.0x27.0x4mm size) and light weight(4.0g) step-down DC-DC converter, which has achieved 22A. Since it can correspond from ultra low output voltage of 0.6V, and set accuracy of output voltage is under $\pm 1\%$, it can be used for the latest DSP, ASIC and FPGA applications. Due to high efficiency and high-speed response by synchronous rectification circuit technology, saving space by no external components, and with SMD package etc. an excellent performance beyond our common sense has been achieved.

<Features>

- | | |
|---|---|
| <ul style="list-style-type: none"> -Ultra Small Size 23x27mm -Low Profile 4.0mm -High-Speed Load Response -Output Voltage Accuracy $\pm 1\%$ -Ultra High Efficiency -Built in Over-Current Protection -Under Voltage Lock Out -Remote ON/OFF Control | <ul style="list-style-type: none"> -Adjustable Output Voltage -Surface Mount Package (SMD) -External Capacitors not required -Heat Sink not required -Non-Isolated Type -Operating Temp. Range -40°C to $+85^{\circ}\text{C}$
(Temp. Derating required) -RoHS Compliance |
|---|---|



<Model / Rating>

Table 1

Model	Input V Vdc	Output V Vdc	Output I A	Output ADJ Vdc	Noise mVpp(typ.)	Efficiency %(typ.)
BSV-1.5S22R0H	3.0 to 5.5	1.5	0 to 22	0.6 to 1.5	30	87

Note1 : The value of ripple and noise and efficiency is the one at input voltage (5V) and rating load.

Note2 : Measurements of ripple noise is performed at BW=20MHz, with an additional multilayer ceramic capacitor of 47 μF to the input and 22 μF to the output.

Note3 : Depending on the ambient air temperature conditions, air flow is required.

<Specification>

Table2

Rating Input Voltage/ Range	Refer to Table 1
Rating Output Voltage	+1.5V $\pm 1\%$ (Trim Pin at open)
Adjustable Output Voltage Range	0.6~1.5V
Line Regulation	0.5% typ. (Rating output, for the regulation of input voltage range on table 1)
Load Regulation	0.5% typ. (Rating input/output voltage, for the regulation of load 0-100%)
Temperature Coefficient	$\pm 0.02\%/^{\circ}\text{C}$ typ. (Input/output rating, for the regulation of operating temp. range -40°C to $+50^{\circ}\text{C}$)
Ripple Noise	Refer to Table 1 (Input/output rating, normal temperature and Bw=20MHz)
Efficiency	87% typ. (Input/output rating, normal temperature. Refer to table 1)
Turn-On Transient	0.5ms typ. (Resistance load)
Max. Output Capacitance	4700 μF max.
Over-Current Protection	Operates at 105% or more rating load current, auto recovery type. Avoid long time short-circuit condition.
Over-Voltage Protection	None
Under Voltage Lock Out	Available
Remote On/Off Control	Between 10pin (ON/OFF) and -6, 9pin (GND): output goes ON when in open, output goes OFF when in short
Standby Current	0.2mA typ.
P-Good Signal	At normal output: high, at output decrease: low, (This terminal is open-drain.)
Remote Sensing	Available
Operating Temp. Range	-40°C to $+85^{\circ}\text{C}$ (Refer to thermal derating graph)
Storage Temp. Range	-40°C to $+85^{\circ}\text{C}$
Humidity Range	20%-95%R.H. max. (Max. wet bulb 35°C , non-condensing)
Storage Condition	For the converter before being mounted, store at $30^{\circ}\text{C}/60\%$ R.H. or below
Cooling Condition	Refer to thermal derating graph
Vibration	5-10Hz All amplitude 10mm, 10-55Hz acceleration 2G (1 hour in each of 3 orthogonal axes)
Shock	Acceleration 20G (3 directions, 3 times each, total : 18 times), Shocking time $11\pm 5\text{ms}$
Weight	4.0g typ.
Outline	SMD type W=23.0 L=27.0 H=4.0 typ. (mm) (For detail dimensions refer to the outline)

*The above specification is provided with rating value, unless otherwise specified

b

1- Application Range

This specifications is applied to the direct current input and non-isolated type DC/DC converter, BSV-1.5S22R0H.

2- Model and rating

Model	Rating Input Voltage	Rating Output	Package type	Note
BSV-1.5S22R0H	DC5.0V	1.5V, 22.0A	SMD	

When the condition is not described in this specifications, it will be that the input is the rated input and the rated output and the ambient temperature is 25°C±5°C

3- Environmental Condition

3-1 Temperature range

At : -40°C to +85°C (Load derating from 55°C is required, only when mounting on a both sided PCB of 100 X 100mm and thickness 1.6mm.)
 Operating :
 At Storage : -40°C to 85°C

3-2 Humidity Range

At Operating : 20~95%RH (Maximum wet bulb temperature is 35°C, and not dew condensation.)
 At Storage : The same as above

Note). Before mounting, it is different from the above mentioned condition.
 Please refer to the section of "Mounting condition" for details.

4. Specification and Standard

This product is a lead free products.

4-1. Input characteristic

Item	Specification and Standard	Terms
Input voltage	+3.0 to 5.5V (Ratings : 5.0V)	
Input current	7.60A typ.	At rating input and rating output
Stanby current	0.2mA typ.	Vin=5.0V, Short between On/Off Pin – GND Pin

The Fifth Generation, Ultra Small Size, Isolated DC-DC Converter

BSV-H22A Series

b

4-2 Output characteristic and attached function

Item	Specification and standard	Terms
Output voltage	1.5V	
Output voltage set accuracy	1.5V±1.0% (±0.015V)	
Adjustable Output Voltage Range	0.6V to 1.5V	Depending on external resistance
Output current	0 to 22A	Derating required
Line Regulation	0.5% typ. (1.0% max)	For regulation of 3.0 to 5.5V input
Load Regulation	0.5% typ. (1.0% max)	For regulation of 0 to 22A load
Temperature Coefficient	±0.02%/°C typ.	For coefficient of -40 to + 35°C
Efficiency	87% typ.	
Ripple Noise	30mVp-p typ. 100mVp-p max.	Bw=20MHz
Over-Current Protection	Operates at 105% or more rating load current, auto recovery type.	Starts and it returns by 50% of ratings the load when the start and O.C. are released.
Over-Voltage Protection	None	
Under Voltage Lock Out	Available Start up voltage : 2.8V±0.2V Shut down voltage : 2.7V±0.2V	Starting up at 3V or more
ON/OFF Control	Open or High (2V or more) – ON Short or Low (0.8V or less) – Off	
P-Good low level voltage	0.4V max	Sink current : 14mA max
Turn-On Transient	0.5ms typ.	Resistance load
Max. Output Capacitance	4700 μ F max	

Note 1) With the measurement circuit of 4-3.

Note 2) Measured by the following conditions without any notice ;

Input voltage : 5V, Output voltage : 1.5V, Output Current : 22A, (Resistance load), Ambient temperature : 25°C±5°C

4-3 Measurement Circuit

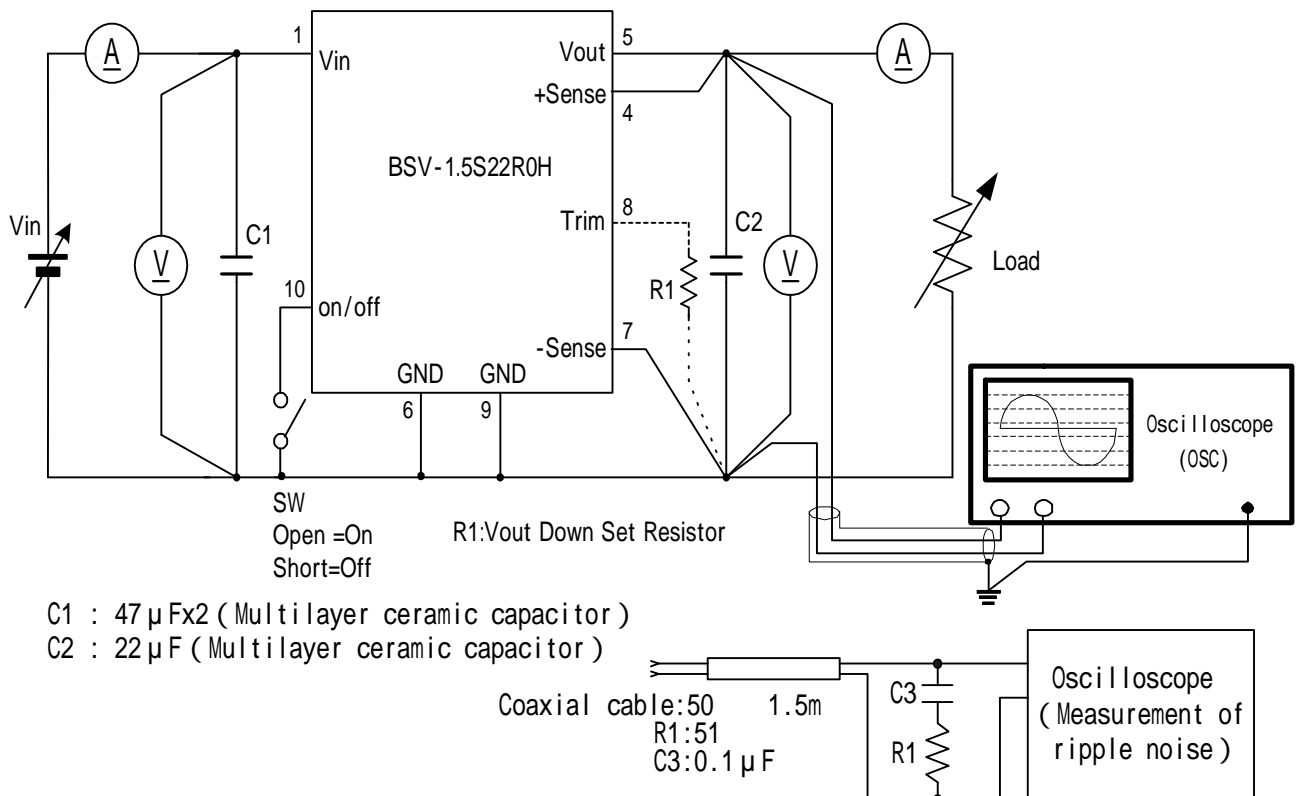

The Fifth Generation, Ultra Small Size, Isolated DC-DC Converter

BSV-H22A Series

b

5. Block Diagram

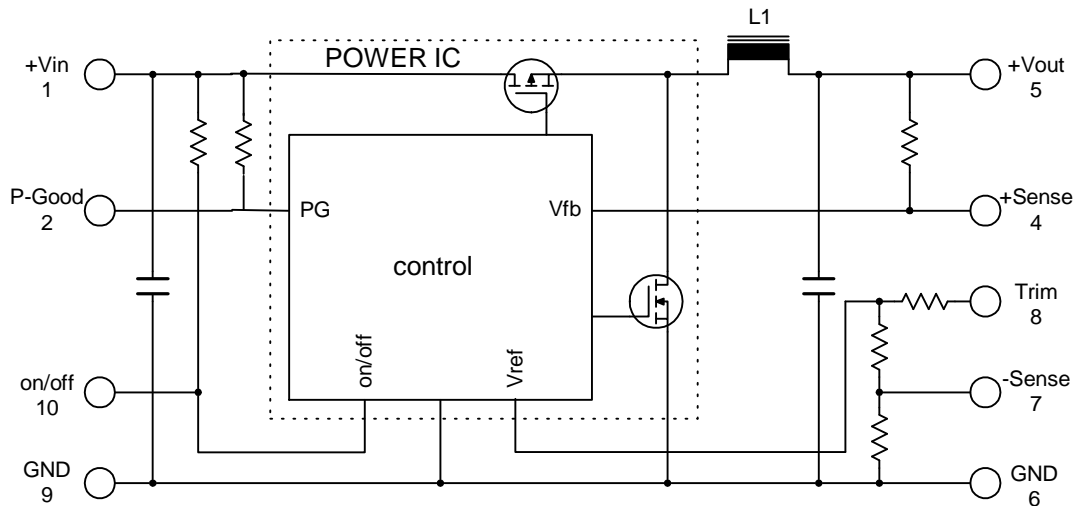

6. Thermal Derating

Set this products in a place where good convection is ensured. And also be sure to mount on a board, when using. This product has been designed to radiate by utilizing the mounted board. So make the line to connect to the converter as wide as possible. The radiation from GND is especially big, so make the GND line wide.

The derating curve below is a data when mounted on a double-side board of copper foil thickness 35 μm, copper foil area 100x100mm (both sides) and thickness of the board 1.6mm. The radiation characteristics will change depending on the wiring, so please refer to the data.

The thermal characteristics for this converter will be largely influenced by the mounted board and the ambient condition. For this reason, finally mount the converter into the device that will be actually mounted. And when it is operated at the maximum ambient temperature of the equipment, be sure that the temperature of the board surface does not exceed 100°C.

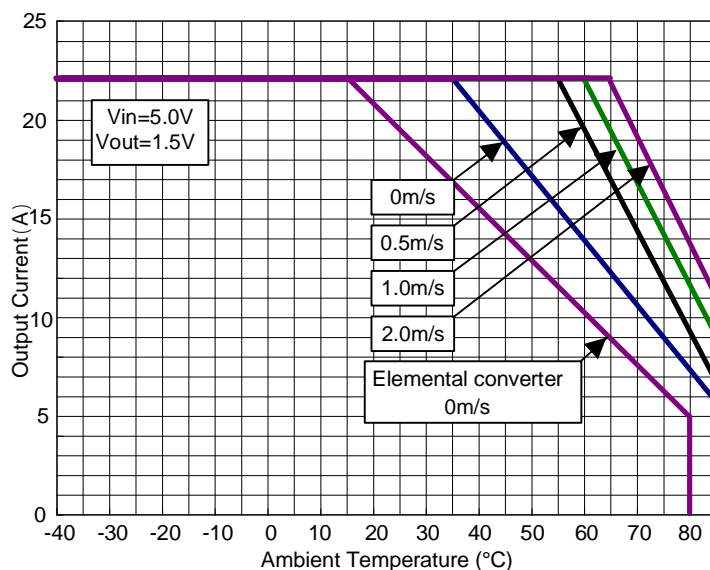

Copper foil area 100 x 100mm The derating curve of substrate is mounted

The Fifth Generation, Ultra Small Size, Isolated DC-DC Converter

BSV-H22A Series

b

7. Outline and Pin Function

7-1. Shape, Outline and Package (SMD type)

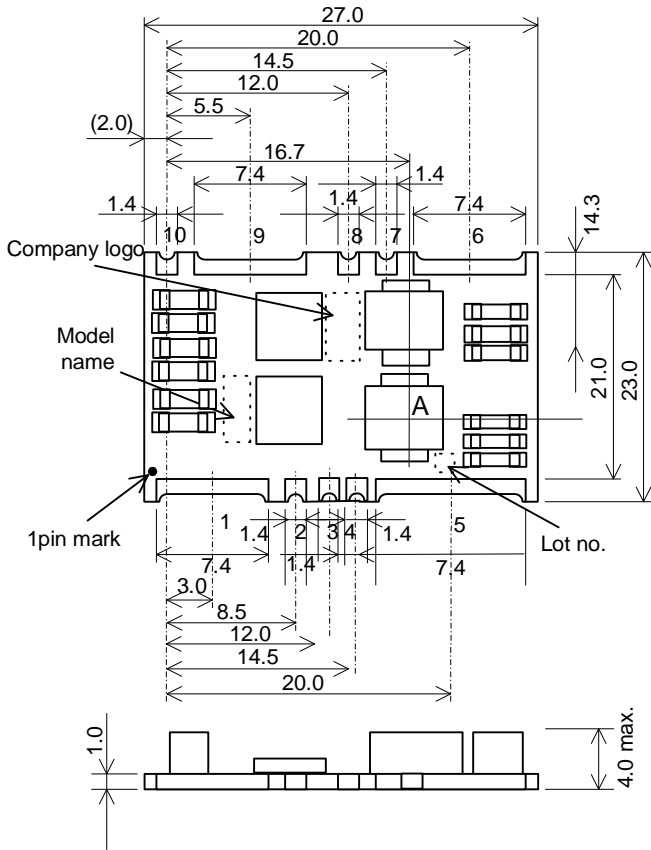

Pin	Function
1	+Vin
2	P-Good
3	NC
4	+Sense
5	+Vout
6	GND
7	-Sense
8	Trim
9	GND
10	On/Off

- Dimensions : mm

- Tolerances unless otherwise specified : ± 0.5

- Weight = 4.0G typ

- The adsorption position uses left chart A point

- It displays "V1.5S22" to the model display to the product

- Lot No. is filled in on 5 pin side.

Mark :

End of A.D.

The manufacturing months (10,11,12,months is O, N, D)

Lot of the months (The first lot is filled in nothing.)

- Flapping of pin 0.2mm max (Floatage of pin when putting it on a horizontal plane)

Note) Be sure to pick up at point A shown in the outline when mounting by an automated machine. Avoid pick up at the component(IC) placed in the center of the board.

7-2. Recommended Pad Layout

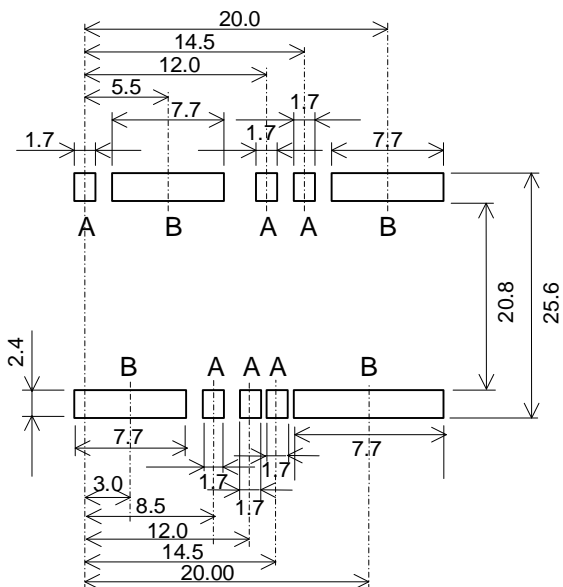

Note) Do not wire a pattern right under the converter (first layer). Since this converter has adopted a normal through-hole board, if there is a pinhole in the resist, it may become a problem.

b

8. Standard Connection Circuit Diagram

8-1. Standard connection circuit

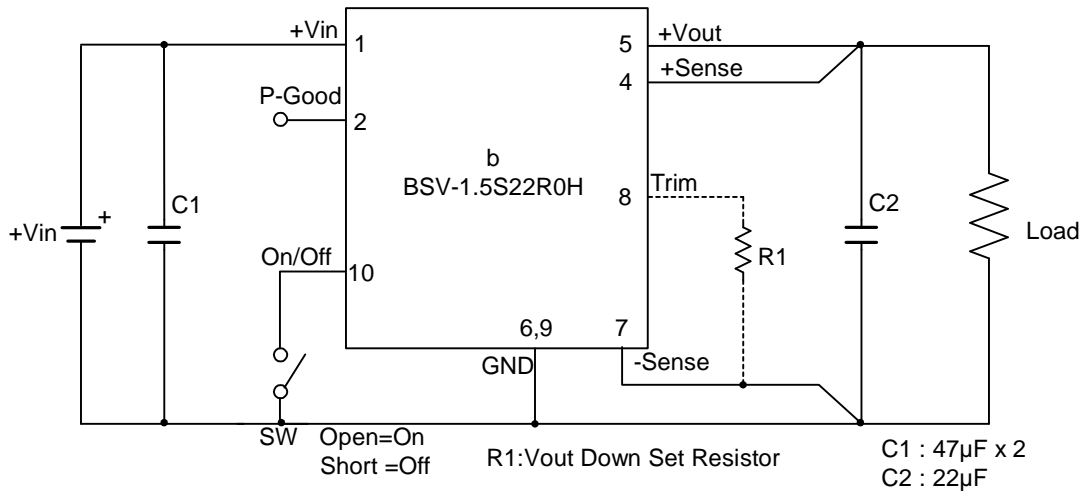

- Note 1) It is a prerequisite for this product to be mounted onto a board, thereby heat relation is done. 70% or more of the heat radiation is done from the GND pin(6, 9pin) and the rest is done from the +Vin pin and +Vout pin. Take space of the pattern as much as possible and design the board to make radiation easy. (Please use that surface temperature of converter's PCB will not exceed 100°C.)
- Note 2) The third pin is check pin when it manufactures. Please install land for the converter fixation and fix on the board. Please do not connect this land with the GND line or +Vin line, etc.
- Note 3) When not using the On/Off control, keep the On/Off pin open.
- Note 4) When not adjusting the output, keep the trim pin open.
- Note 5) GND pin (6, 9pin) is connect inside, however to secure the performance, use it with the 2 pins connected to the GND line.
- Note 6) Be sure to connect the sense pin and output pin on the board. Unless the sense pin is connected, there is a possibility that a higher voltage than the rating voltage may be output.
- Note 7) Do not wire a pattern right under the converter (first layer). For other layers wiring a pattern will be no problem.

Recommended Capacitor

C1=47 µ F x 2

C2=2.2 µ F ~200 µ F

C1 : It is unnecessary if impedance of the power supply on the input side is low enough and the power supply on input side is connected by the enough thick and short line, however, it is necessary if the impedance is high. Use ones with low ESR such as organic semiconductor solid capacitor, multilayer ceramic capacitor.

C2 : The converter will operate without C2 because the output capacitor has built in, however, it is necessary to satisfy with the electric characteristic (Ripple Noise). The connecting to the load side will make noise decrease. Use a multilayer ceramic capacitor.

b

8-2. ON/OFF Control

By using the ON/OFF control function, ON/OFF of the output without connecting and disconnecting the input can be controlled. ON/OFF Pin (9pin) has been connected with +Vin terminal internally by the resistance of 22k . When not using the ON/OFF control, keep the ON/OFF pin open.

Between ON/OFF pin (10pin) and GND (9pin)
 Open : Output=ON
 Short (0 to 0.8V 0.3mA max.) : Output=OFF

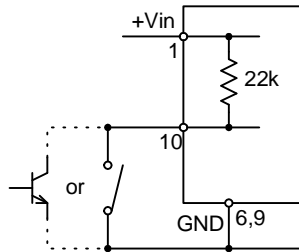

8-3. Adjusting Output Voltage

When using at 1.5V without adjusting output voltage, keep Trim pin (8pin) open. By connecting a resistor between Trim pin (8pin) and -Sense pin (7pin) , the output voltage can be adjusted within the range of 0.6-1.5V. Connect -Sense pin to GND (6pin).

When adjusting the output voltage, place the Rx close to the converter and make the wiring of Rx as short as possible. If the Trim pin catches noise, malfunction may occur.

To calculate the external resistance, please refer to the equation below. After calculating the external resistance, please check the output voltage and adjust the resistance value.

To set within the range of 0.6V-1.5V

$$R_x = \frac{R_2 \times V_{out}}{I_1 \times R_2 - V_{out}} \quad R_1(\Omega)$$

Ex.)

Desired Output Voltage Vout (V)	Rx Calculated Value (k ohm)
1.5	Open
1.2	183.39
1.0	80.29
0.8	35.74
0.6	10.90

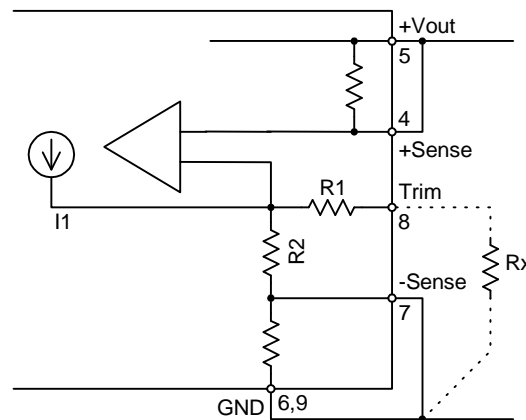

R1=24k ohm, R2=52.6k ohm, I1=0.0286mA, Vout=Requested output voltage (V)

b

8-4. Sensing function

An excellent load regulation characteristic can be obtained by using the sensing function on the load side. Enough attention is required for wiring because the sensing line is a part of the feedback loop, and it is very sensitive. Please wire +Sense and –Sense close together to the load.

Please connect the +Vout Pin and +Sense Pin, -Vout Pin and –Sense Pin respectively on the PCB when not using the sensing function.

8-5. P-Good Function

By utilizing this P-Good pin, the output condition of the converter can be obtained. This terminal is open-drain. If using P-Good function, please use P-Good terminal connecting the resistor outside and pulling-up to the input voltage.

It will be open by

|Output voltage-Set voltage| 0.2V typ.

However, under the conditions written below, even if the output voltage is within this range, it may become low.

- When the input voltage is below 3V
- When the output current is at over-current state.
- When the IC temperature is above 100°C

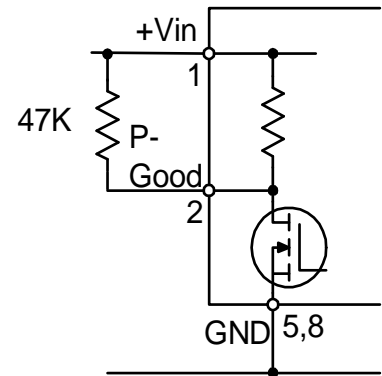

The Fifth Generation, Ultra Small Size, Isolated DC-DC Converter

BSV-H22A Series

b

9. To prevent reverse input voltage protection(Ex.)

This product is a non-isolated type DC-DC converter that steps-down from (+) to (+).

If the input voltage reversed is connected by mistake, it will be damaged.

If there is a possibility of reverse connection, please add a protection as shown in the right figure. The right figure is an example using fuse and diode.

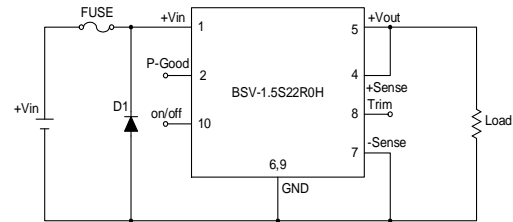

10. Over-Voltage Protection Diagram (Ex.)

This product does not have a built-in over-voltage protection. If the switching element in this converter is damaged in short mode, DC input voltage will go out as output.

To avoid damage at over-voltage mode, in advance, please add the input interrupting circuit as the right figure.

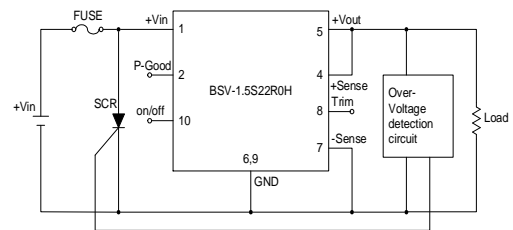

Note 1. When it is damaged at over-voltage mode, ON/OFF control will not operate.

Note 2. When having ON/OFF function on the supplying power side, this circuit can be used.

Note 3. Be sure that the DC power supply on the supplying side has the capacity to cut the fuse.

b

11. Soldering Conditions

Please conduct by the condition as below regarding the soldering temperature and time and storage before mounting.

11-1. Reflow method

Pre-heating temp.: 150-180°C, within 60 sec max. (Refer to the figure below)

Peak heading temp.: 250°C max.
220°C or more, within 60 sec max.

Reflow: twice

Note 1. Do not give shock at reflow because components which compose the converter may move.

Note 2. After mounting the converter on PCB, please do not reflow again turning the PCB over.

Note 3. This converter cannot be soldered by flow.

11-2. About storage before being mounted

When you open dry packing, storage conditions before being mounted should be 30°C/60% RH or below. Moreover, baking (125°C±5°C, 12H) is needed before the reflow when it is one year while dry packed and dry packing is opened with 30°C/60% RH above 168 hours.

After mounting, it depends on the environmental condition.

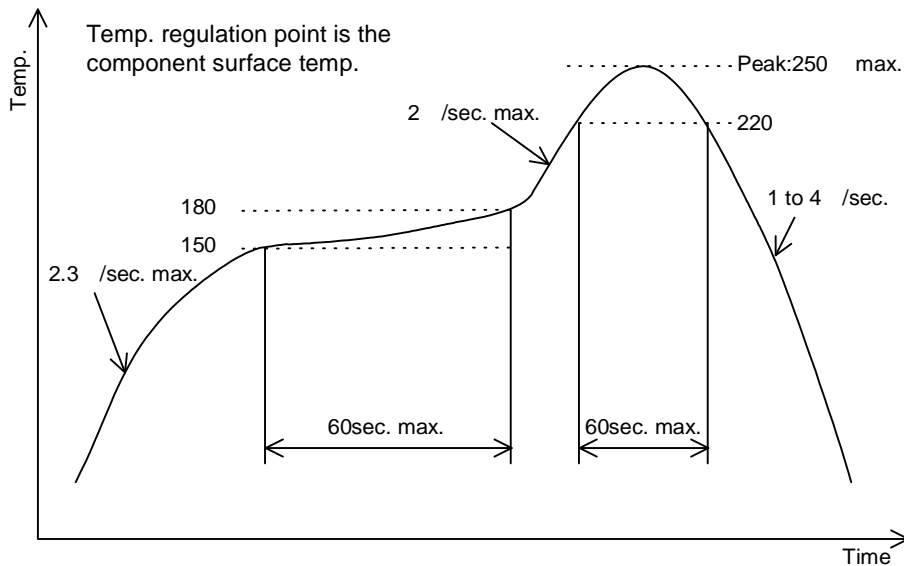

12. Vibration and shock test

Vibration : 5~10 Hz All amplitudes 10mm, 10~55Hz Acceleration 2G (Three direction, for one hour each)

Shock : Acceleration 20G (Three direction, three times each)

Shocking time 11±5ms

13. Cleaning Conditions

This product can not be washed whole. No-clean solder paste is recommended for this product.

14. Precautions

For customer's safety, when using this product, please refer to the specification and please use keeping the following precautions surely.

- This product is for being used in general electric equipments (business equipments, telecommunication equipments and measurement equipment).

Can not be used in medical equipments, nuclear equipments and trains which would affect lives or properties directly by the failure of this product.

Be sure to contact our sales when using in besides general use.

- For this product parallel and series operation are not possible.

- For mounting this product, please do not use connector of socket. The performance may not be fulfilled due to the effect of contacting resistor.

Mount to print board by soldering.

- This product has a built-in over-current, short protection, but long time short circuit will cause failure, so please avoid it.

- There is possibility of damage when used under electric conditions and environmental conditions such as temperature that are out of the standards.

Be sure to be use within the standards.

- Do not store in a place where corrodible gas may be generated or a dusty place.

- There is possibility of damage by static. When the worker has electrified static, electrical discharge should be done and the working on the table so grounded may be recommended.

- This product does not have a built-in fuse. Connect a fuse to the +input line for protection when over-current flows into input at abnormal. Please be sure that the supplying power has the capacity to fuse the fuse.

- This product does not have a built-in over-voltage protection. When over-voltage occurs due to the abnormality in the module, there is a mode that input voltage comes out at it is, and may cause smoke and ignition. To prevent this, be sure to add over-voltage protection.

- No test result certificate attached to this product.

15. Guarantee

The guaranteed term of this product is one year. When occurring any failure mode by the cause of our design and production in this guaranteed term, we will repair the failure product or replace to the good product by free of charge.

However, when being remodeled inside etc., we shall not guarantee it.

The range of the guarantee for this product is the one of this products concerned.