



15 Watt BSI-24 Series

Ultra High Efficiency POL DC-DC Converters/ BSI 24V Input Voltage 15Watt Series

Ultra High Efficiency (87%, 91%), Minimum Size Step-Down DC-DC Converter

Input: +8V, +12V, +15V, +24V Output: +3.3V (+1.2V to +5.1V)

- Efficiency 87%-91%
- Input Voltage Range +8V to +27V
- Output Voltage Range +1.2V to +5.1V
- Latest Technology, Synchronous Rectification Circuit
- Adjustable Output Voltage
- Non-Isolated Type Converter
- Short Circuit, Over-Current Protection
- No Electrolytic Capacitor, No Tantalum Capacitor
- Heat Sink Not required, 15W
- Minimum Size
- Remote ON/OFF Control
- MTBF 1,000,000Hrs
- High Reliability, High Performance
- Operating Temp. Range -10°C to +70°C (Temp. derating required)
- RoHS Compliance

Models BSI Series	Input V Vdc	Output V Vdc	Output I A	Line Reg %(typ.)	Load Reg %(typ.)	Ripple/Noise mVpp(typ.)	Efficiency %(typ.)
BSI24-3.3/5S3R0	8-27	3.3 (1.2-5.1)	0-3	0.3	3	40 (50)	87 (91)
BSI24-3.3/5S3R0F							

Note 1: The output voltage inside the () indicates the adjustable range.

Note 2: Ripple noise () value, efficiency () value is at input voltage 5V.

Note 3: External capacitors are required.

<Outline> (SIP Type)

BSI24-3.3/5S3R0

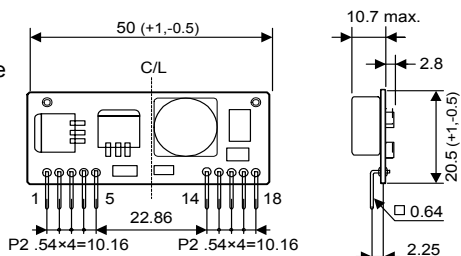

(DIP Type)

BSI24-3.3/5S3R0F

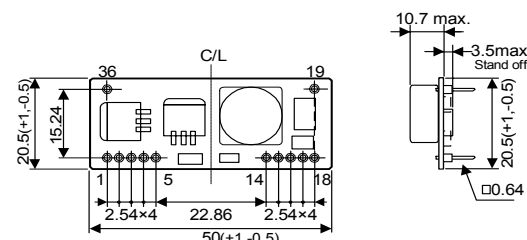

pin	Function
1	+Vin
2	+Vin
3	-Vin
4	-Vin
5	ON/OFF
14	V.ADJ
15	-Vout
16	-Vout
17	+Vout
18	+Vout

pin	Function
1	+Vin
2	+Vin
3	-Vin
4	-Vin
5	ON/OFF
14	V.ADJ
15	-Vout
16	-Vout
17	+Vout
18	+Vout
19	NC
36	NC

- Note!

This catalogue is an outline of the products.

When designing, be sure to refer to the data sheets.

Weight: 10g typ.
Dimensions: mm

Weight: 11g typ.
Dimensions: mm

<Standard Connection Circuit Diagram>

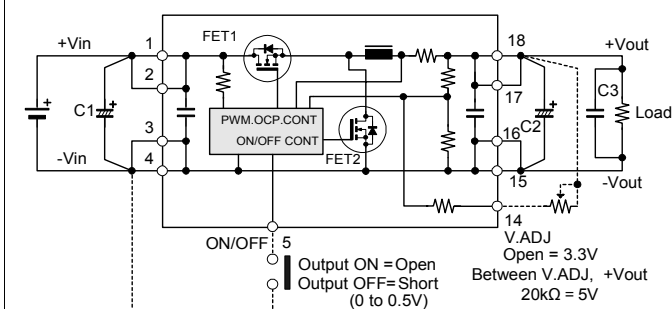

- External Capacitors

C1 should be 330μF or higher and an of impedance 81mΩ (20°C/ 100kHz) or below.

Recommend: Electrolytic Capacitor

C2=150μF (ESR = 28m Ωor below) ×2 or more

Recommend: OS-CON

To set the output voltage for 3.1V or lower, use three OS capacitors (different from the one written above).

- ON/OFF Control

ON/OFF is controlled by opening and shortening between the 5pin(ON/OFF) and 3, 4pin (-Vin).

Be sure to maintain a slew rate of 0.03V/ μs or more while the voltage is around 1V during start up and shut down.

- Adjustable Output Voltage

The output voltage is adjustable by connecting a resistor between 14pin (V.ADJ) and 17, 18pin (+Vout).

When 14pin is open, the following rated output voltage is as follows

Output = +3.3V±5%