

The product is a step down DC-DC converter that has a feature to change settings such as output voltage, turn-on sequence and turn-off sequence via serial communication (PMBus) during operation. Furthermore, the product is equipped with digital control feature achieving high output voltage accuracy.



**■ Features**

- Output Voltage Accuracy  $\pm 0.5\%$
- High Efficiency 90%
- Small foot print, high power density
- Non-Isolated type
- Overcurrent protection
- Under Voltage Lock Out
- ON/OFF Control
- Adjustable Output Voltage (via PMBus)
- Output Overvoltage Protection
- Parallel Operation (via PMBus, Derating required)
- 2 types of Serial Communication Buses
- Settings can be changed and monitored during operation via serial communication (PMBus)
- Turn-on and turn-off sequences can be configured (via PMBus)
- High current balance in parallel operation is achieved via serial communication (using exclusive Bus)
- High reliability, High performance
- SMD package
- Operating temperature  $-40^{\circ}\text{C}$  to  $+85^{\circ}\text{C}$  (Temperature derating required)
- RoHS compliant

**■ Rating**

Table 1

Models BDP Series	Input V Vdc	Output V Vdc	Output I A	Line Reg. %(typ.)	Load Reg. %(typ.)	Noise mVpp(typ.)	Efficiency %(typ.)
<b>BDP12-0.6S150R</b>	12V (8.0 to 14.0)	1.2 (0.5 to 1.5)	0 to 150	0.2	0.2	15	90

Note 1 : Unless otherwise specified, the product is measured at input voltage 12V, output voltage 1.2V, output current 150A, ambient temperature  $25^{\circ}\text{C}\pm 5^{\circ}\text{C}$ .

Note 2 : Efficiency is measured at input voltage 12V, output voltage 1.2V, output current 150A, ambient temperature  $25^{\circ}\text{C}\pm 5^{\circ}\text{C}$ .

Note 3 : Ripple noise is measured at BW=20MHz.

Note 4 : Depending on ambient temperature, temperature derating and forced air cooling may be required.

**■ Specification**

Table 2

Input voltage range	Refer to Table 1
Rated input voltage	12.0V
Rated output voltage	1.2V
Default preset output voltage	0.6V
Adjustable output voltage range	Refer to Table 1
Output voltage accuracy	$\pm 0.5\%$
Line regulation	Refer to Table 1 (Rated output, Input voltage varying in the range of Table 1)
Load regulation	Refer to Table 1 (Rated input/output voltage, Load varying from 0 to 100%)
Ripple noise	Refer to Table 1 (Rated input/output, measurement frequency bandwidth 20MHz)
Efficiency	90% typ. (Rated input/output, 150A output, Refer to Table 1)
Overcurrent protection	Yes
Under voltage lock out	Yes
Output overvoltage protection	Yes
Remote ON/OFF	Yes
P-Good signal	Yes
Remote sensing	Yes
Operating temperature range	$-40^{\circ}\text{C}$ to $+85^{\circ}\text{C}$ (Refer to temperature derating described separately)
Storage temperature range	$-40^{\circ}\text{C}$ to $+85^{\circ}\text{C}$
Humidity	20 to 95%R.H. (Max. wet bulb temperature $69^{\circ}\text{C}$ with no condensation)
Storage condition	Below $30^{\circ}\text{C}$ /60% R.H before mounting
Cooling condition	Refer to temperature derating described separately
Weight	23.92g typ.
Outer dimensions	W=28.2 L=43.7 H=10.0 (mm) (Refer to outer dimensions described separately)

\* The above specifications are provided with rated value, unless otherwise specified.

\* The contents provided in this datasheet may be changed at any time without prior notice.

## 1. Scope

These specifications shall apply to the non isolated type DC-DC converter, BDP12-0.6S150R series.

## 2. Model/Rating

Model name	Rated input voltage	Rated output	Shape	Remarks
BDP12-0.6S150R	DC12.0V	1.2V, 150A	SMD	

Unless otherwise mentioned in the specifications, input shall be rated input, output shall be rated output, and ambient temperature shall be 25°C±5°C.

## 3. Environmental conditions

## 3-1 Temperature range

In operation	-40°C to +85°C (Derating required)
In storage	-40°C to +85°C

## 3-2 Humidity range

In operation	20 to 95%R.H. (However, max. wet bulb temperature 69°C, no condensation)
In storage	20 to 95%R.H. (However, max. wet bulb temperature 69°C, no condensation)

Note) Store in a place below 30°C/60% R.H. before mounting.

## 4. Specifications &amp; Standards

The product is RoHS compliant.

## 4-1 Input characteristics

Item	Specifications & Standards	Conditions
Input voltage	+8.0 to 14.0V (Rating 12.0V)	

## 4-2 Output characteristics and functions

\*1, \*2

Item	Specifications & Standards	Conditions
Rated output voltage	1.2V	*3
Output voltage by default	0.6V	
Output voltage tolerance	1.2V±0.5% max.	Output current at 0A
Adjustable output voltage range	0.5 to 1.5V	Configured via Serial communication
Output current	0 to 150A	Derating required
Line regulation	0.2% typ. 0.5% max.	Input varying from 8.0 to 14V
Load regulation	0.2% typ. 0.5% max.	Load varying from 0 to 150A
Temperature regulation	±0.003%/°C typ.	Temperature varying from -40 to +85°C upon output current at 75A
Integrated regulation	±1.0% max.	Including input regulation, load regulation, temp. regulation ※4
Ripple noise	15mVp-p typ. 50mVp-p max.	BW = 20MHz
Efficiency	90% typ.	Input voltage 12V Output voltage 1.2V Output current 150A
Overcurrent protection	Operate at 105% or above (auto restart type)	Threshold can be configured via serial communication
Maximum output capacitance	8000uF max.	*5
Under Voltage Lock Out	Yes Activation voltage: 7.5V typ. Deactivation voltage: 7.0V typ.	
ON/OFF control	Between the ON/OFF pin - the GND pin ON when open OFF when short circuit or low	Refer 8-7-1 when the pin is open or check the voltage at Low status.
P-Good output	At normal output: Open At low output: Low	Refer 8-10 when the pin is open or check the voltage at Low status.
Output overvoltage protection	Auto restart type	
Communication feature	Yes (PMBus Rev.1.2 compliant)	
Sequence feature	Yes (via Serial communication)	
Monitoring feature	Yes (via serial communication)	
Parallel operation	Yes (via serial communication)	*6
Oscillation frequency setup	No	250kHz×4Phase

\*1 With measurement circuit of 4-3.

\*2 Unless otherwise specified, the following measurement conditions will apply.

Input Voltage 12.0V, Output Voltage 1.2V, Output Current 150A, and Ambient Temperature 25°C±5°C,

\*3 Output voltage is set at 0.6V by default and can be changed via serial communication.

\*4 Value is designed value.

\*5 Maximum output capacitance depends on the output voltage and turn-on time when start-up, and a characteristic of added capacitor. Make sure to check with the actual device. Contact to us if you need to increase the output capacitance more than maximum capacitance.

\*6 Parallel operation is disabled by default and can be enabled via serial communication.

4-3 Measurement circuit

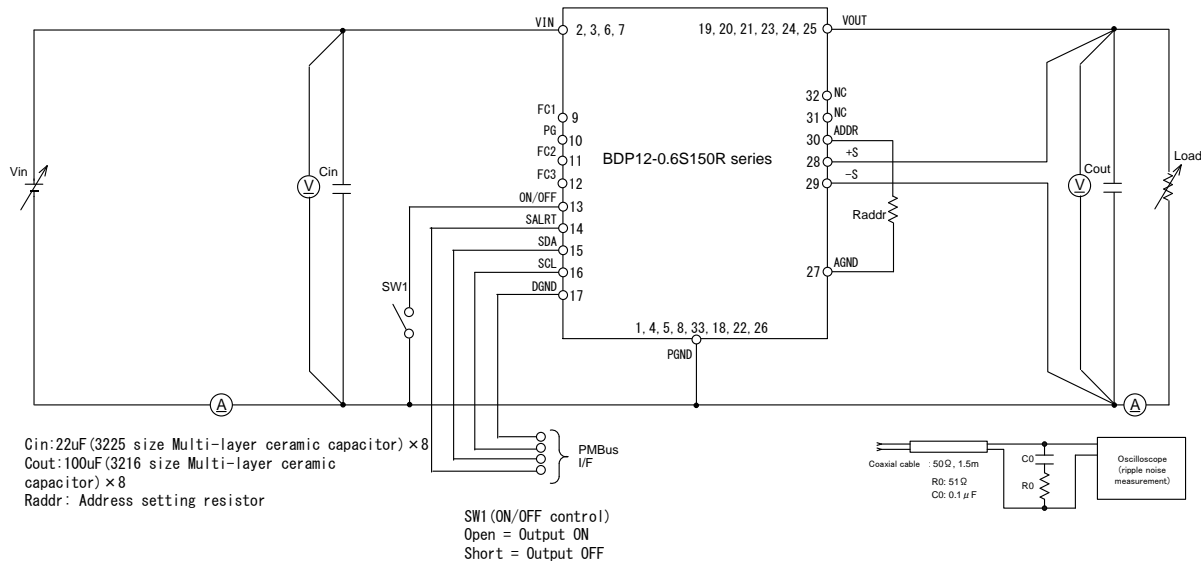

5. Temperature derating

Install the product in a well-ventilated place.

Implement derating appropriate to usage environment.

Derating shall be according to ambient temperature and input voltage.

Temperature of the converter varies substantially depending on the board it is mounted on and on the ambient temperature. Ultimately, therefore, mount the converter onto a device which will actually be used with the converter. When operated with the actual equipment at the highest ambient temperature, temperature of the converter must not exceed the absolute maximum rating (115°C max.).

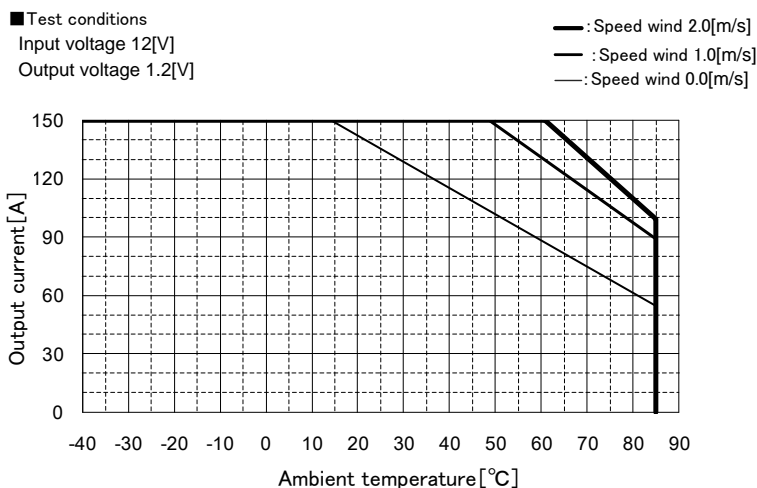

<Heat release pattern conditions>

Copper foil coating of 120 x 120 mm in dimension and 70µm thickness when mounted on a four-layered board

<Air-flow direction, Condition of measuring temperature>

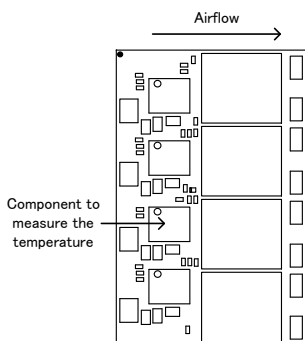

6. Outer dimensions and description of pins

6-1 Shape and dimensions

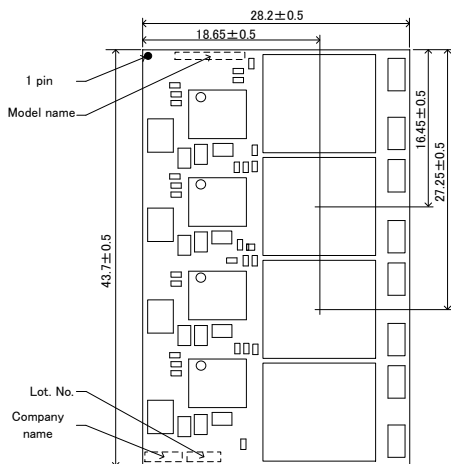

Unit : mm  
Dimensional tolerance:  $\pm 0.5$ mm

Top View

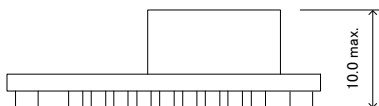

Side View

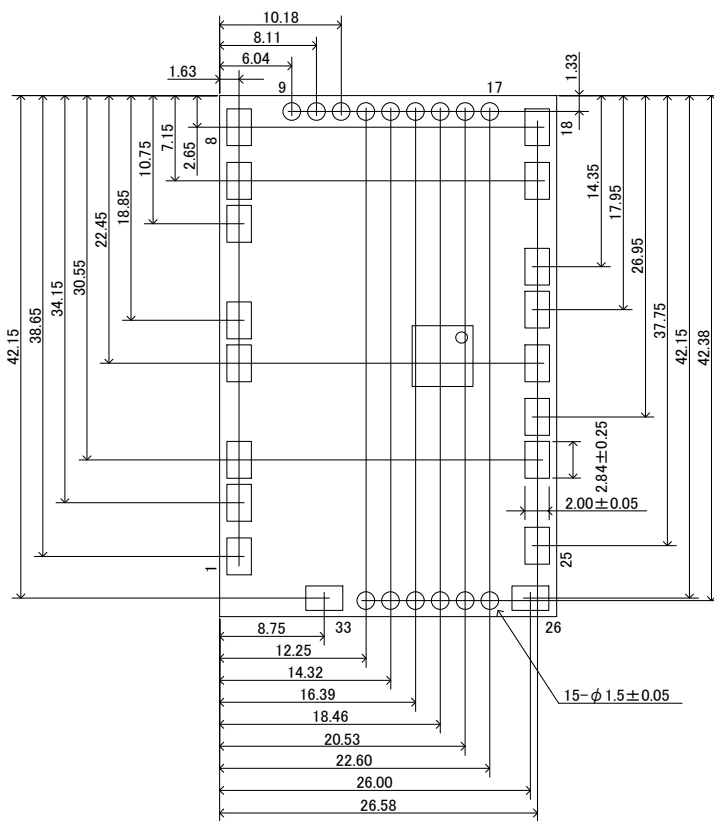

Bottom view

Round pin space: 0.2mm or more 0.94mm or less

6-2 Recommended Footprint

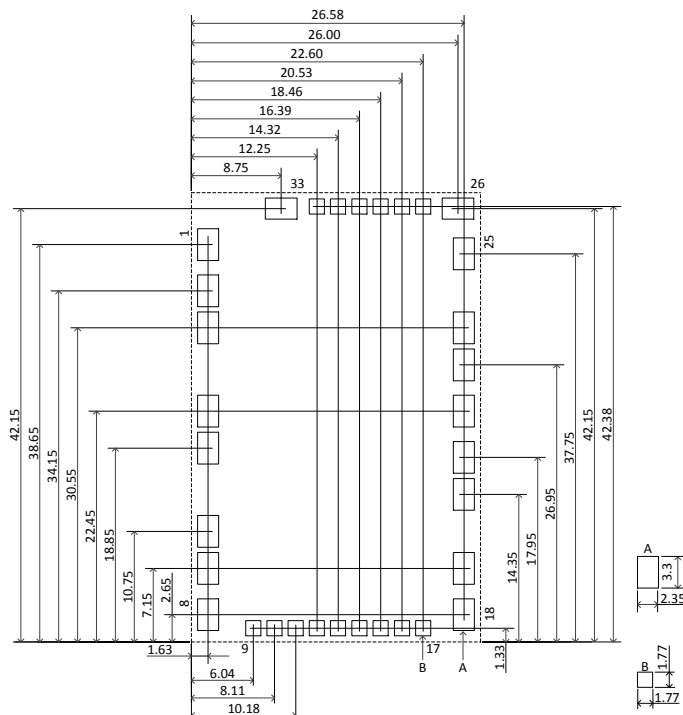

(A) Corner pin 1 to 8, 18 to 26, 33pin

(B) Round pin 9 to 17, 27 to 32pin

Note) Recommended layout is shown above. Use your design standard for your specific design.

6-3 Description of pins

Pin	Name	Function
2, 3, 6, 7	VIN	Voltage input pin
1, 4, 5, 8, 33	PGND	Power ground pin
9	FC1	Function pin 1
10	PG	Power good output pin
11	FC2	Function pin 2
12	FC3	Function pin 3
13	ON/OFF	Remote ON/OFF pin
14	SALRT	Serial alarm pin
15	SDA	Serial data pin
16	SCL	Serial clock pin
17	DGND	Digital ground pin (connected to GND pin internally)
18, 22, 26	PGND	Power ground pin
19,20,21, 23,24,25	VOUT	Voltage output pin
27	AGND	Analog ground pin (connected to GND pin internally)
28	+S	(+) Remote sensing pin
29	-S	(-) Remote sensing pin
30	ADDR	Address setting pin
31	NC	No Connection (No electrical connection made)
32	NC	No Connection (No electrical connection made)

6-4 Lot indication

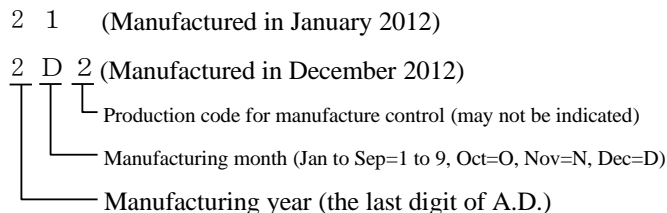

7. Standard connection diagram

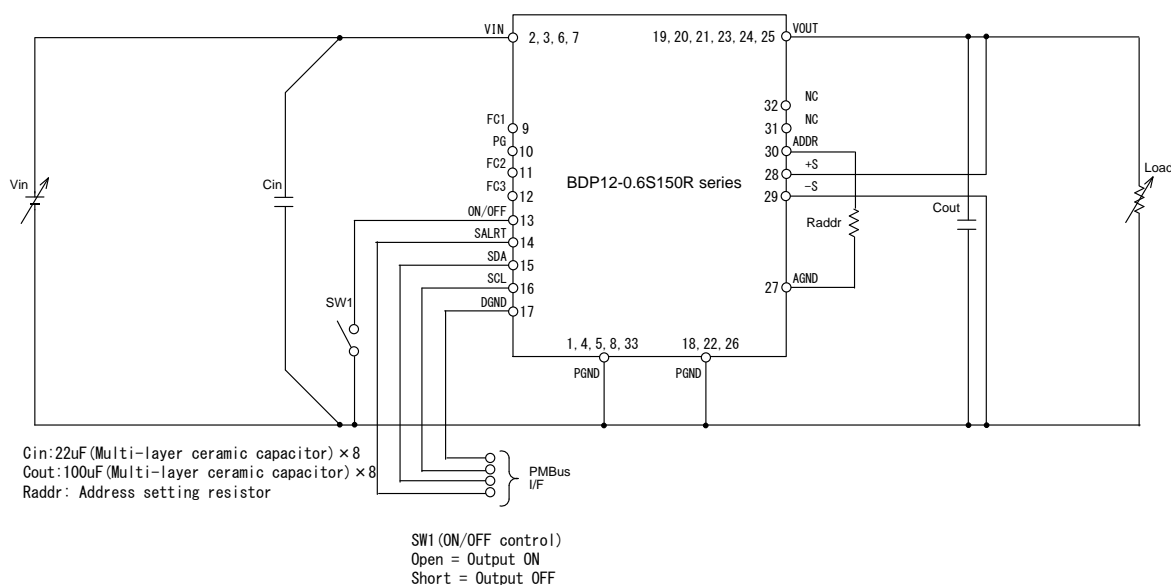

- Note 1: Make sure to connect the +S and -S pins to the converter.
  - Note 2: Raddr is a resistor to set a device address via serial communication. Make sure to install an appropriate resistor for the required address.
  - Note 3: Leave the SALRT, SDA, SCL, DGND pins open when not used.
  - Note 4: Leave the PG pin open when not used.
  - Note 5: Make sure to add input/output capacitors (Cin, Cout) as close to the root of the converter as possible.
  - Note 6: Wire between the input power and the converter in order to lower line impedance. If the line impedance gets high, connect the capacitor which has appropriate capacity to operate stable input voltage and Cin in parallel.
  - Note 7: The converter may not start up if output capacitor, Cout is added depending on size of the output capacitor. Make sure to check with the actual device.
  - Note 8: Connect the VIN pin(2,3,6,7 pin) and VOUT pin (19,20,21,23,24,25 pin) by solid pattern as close to the converter pin. (Refer to below layout)
- Below reference layout only shows the mounting surface. Design the pattern in consideration of actual use current value and ambient temperature etc.



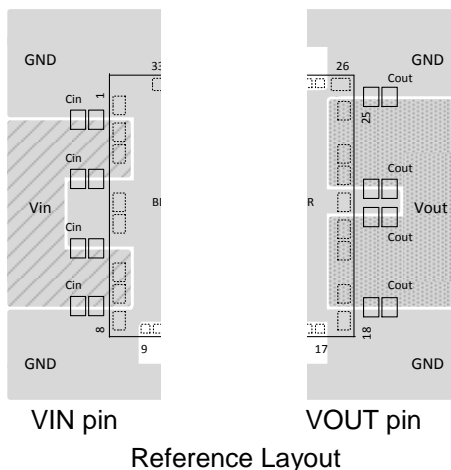

8. Functions

8-1 Digital Control

The PMBus communication interface (serial communication) allows output voltage, sequence and other product settings to be changed and information such as input voltage and output voltage to be obtained. Values configured via serial communication should be taken as the targeted ones which could differ from the actual values due to product variations.

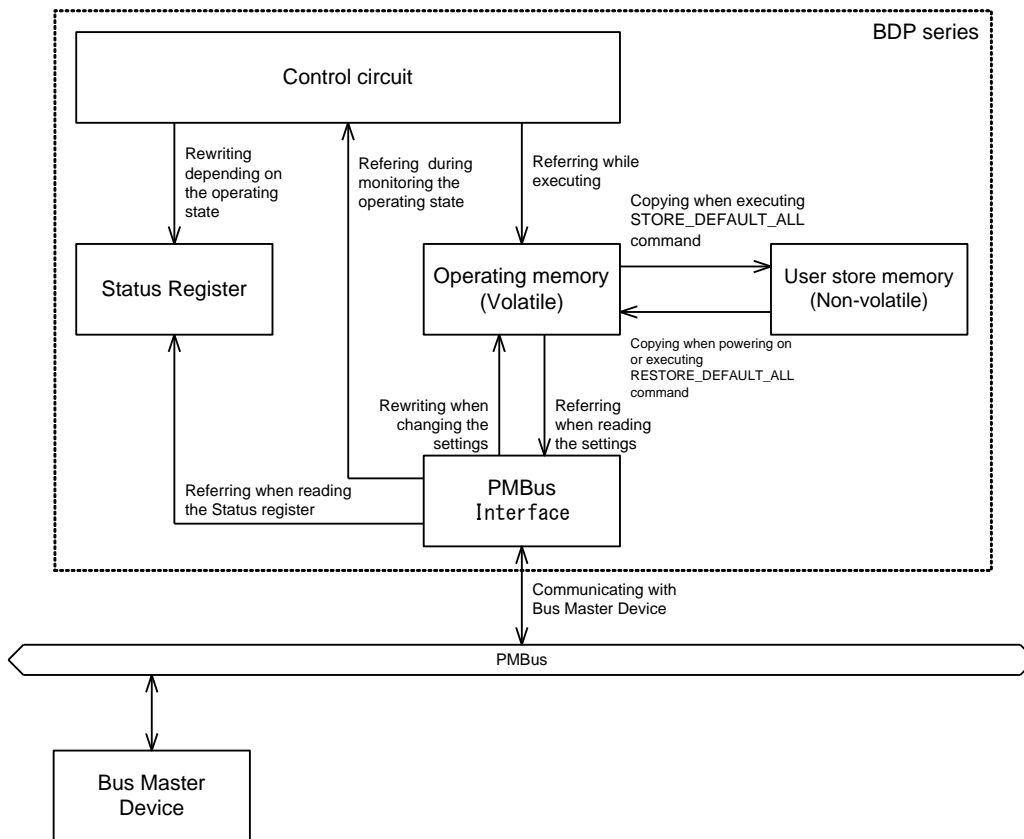

Digital control conceptual diagram

### 8-1-1 Internal Memory

The product contains volatile operating memory and non-volatile user store memory. Settings for the converter are stored in the user store memory and the settings are copied from the user store memory to the operating memory during start-up.

Control circuit of the product reads the contents of the operating memory. The contents can be re-written when the settings are changed via serial communication. Because the operating memory is volatile, the changed settings in this memory are lost when the product is turned off.

In order to keep the changed settings after the turn off, the settings need to be stored in the non-volatile user store memory via the STORE\_DEFAULT\_ALL command.

The RESTORE\_DEFAULT\_ALL command allows the contents of the user memory to be copied back to the operating memory (restoring the contents of the operating memory that existed before the previous STORE\_USER\_ALL command was executed).

Note: Since non-volatile memory is anti fuse type, the free memory space will decrease every time the settings are stored in the memory. The use of command, STORE\_DEFAULT\_ALL command should be limited to twice.

Items	PMBus commands
Storing the setting value	STORE_DEFAULT_ALL
Restoring the setting value	RESTORE_DEFAULT_ALL

### 8-2 Output Voltage Setup

This output voltage can be changed in the range between 0.5 to 1.5V only via serial communication, not via an external resistor. Output voltage other than the default setting can only be changed via serial communication.

Item	PMBus command	Adjustment range	resolution	Default setting
Output voltage	VOUT_COMMAND	0.5 to 1.5V	195uV	0.6V

**8-3 Margin State**

The product has 3 margin states, Margin OFF, Margin HIGH and Margin LOW when setting output voltage. Different output voltage can be set to each Margin state and the output voltage is adjusted to the value of the preset margin state at that time.

Output voltage can be set independently on each Margin State in the range between 0.6 to 1.5V via serial communication.

Items	PMBus commands	Range	Resolution	Default setting
Output voltage in the Margin OFF State	VOUT_COMMAND	0.6 to 1.5V	195uV	0.6V
Output voltage in the Margin High State	VOUT_MARGIN_HIGH	0.6 to 1.5V	195uV	0.6V
Output voltage in the Margin Low State	VOUT_MARGIN_LOW	0.6 to 1.5V	195uV	0.6V

The default margin state setting is off.

The margin state can be switched to Margin High or Margin Low via serial communication when temporal voltage change is required.

Item	PMBus command	Default setting
Switching Margin States	OPERATION	Margin OFF

#### 8-4 Output Voltage Trimming

This function allows output voltage to be increased or decreased in the range mentioned below via serial communication.

Item	PMBus command	Setting range	Resolution	Default setting
Output voltage trimming	VOUT_TRIM	-0.9V to 0.9V	195uV	0V

#### 8-5 Output Voltage limit

This function enables output voltage to be set at the highest level that can be configured via the VOUT\_COMMAND, VOUT\_MARGIN\_HIGH or VOUT\_MARGIN\_LOW commands.

It caps output voltage at the preset level in case of excessive output voltage accidentally being applied. It has no connection with the overvoltage protection feature.

Item	PMBus command	Setting range	Resolution	Default setting
Output voltage limit	VOUT_MAX	0.6 to 1.6V	195uV	1.6V

#### 8-6 Remote Sensing

This function allows excellent load regulation characteristics to be obtained on the load side. The sensing line is a part of the feed back loop and is very sensitive, thus extra care must be exercised when routing a pattern. Route the +S and -S pins side by side and connect the pins to the load.

Make sure to connect between the Vout and the +S pins as well as connect between the PGND and the -S pins when not used.

#### 8-7 ON/OFF control

This function allows output voltage to be turned on and off without switching the input on or off physically. It can be controlled by two methods, one is using the ON/OFF pin and the other is by serial communication.

The ON/OFF control can be set to “enabled” or “disabled” by each method. By default, the ON/OFF control is set to “enabled” only via the ON/OFF pin.

Note: The ON/OFF control has a characteristic that the OFF state supersedes the ON state.

The ON/OFF controls via both the ON/OFF pin as well as serial communication require to be set to “enabled” and configured as “ON” in order to produce output.

## 8-7-1 ON/OFF control via the ON/OFF pin

Output voltage can be controlled on or off by opening or short-circuiting between the ON/OFF pin and the GND pin. Open circuit voltage of the ON/OFF pin is 3.3V typ.

When using the ON/OFF pin to turn off the output, switching can be terminated immediately or after a sequence has been applied. Whichever the method to be applied can be configured via serial communication (ON\_OFF\_CONFIG command). The default setting is to terminate switching immediately.

Between the ON/OFF pin – GND pin
OPEN
SHORT (0 to 0.8V, 0.35mA max.)

Note: Make sure not to generate chattering between the ON/OFF and GND pins.

## 8-7-2 ON/OFF control via serial communication

Output voltage can be controlled on or off via serial communication. When using serial communication to turn off output, switching can be terminated immediately or after a turn-off sequence has been applied.

Items	PMBus commands	Default settings
ON/OFF control via serial communication	OPERATION	Output OFF
Operation setting of ON/OFF control	ON_OFF_CONFIG	ON/OFF control - Enabled (the ON/OFF pin) ON/OFF control - Disabled (serial communication) Sequence is disabled when output is turned off via the ON/OFF pin

8-8 Sequence setup

This function allows the items below to be configured.

- Turn-on Delay
- Turn-on Rise
- Turn-off Delay

Turn-on delay is a period from when the ON command is issued by the ON/OFF control (via the ON/OFF pin or serial communication) until output voltage begins increasing. (See the figure below)

The turn-off delay is a period from when the OFF command is issued by the ON/OFF control (via the ON/OFF pin or serial communication) until output voltage begins decreasing. (See the figure below)

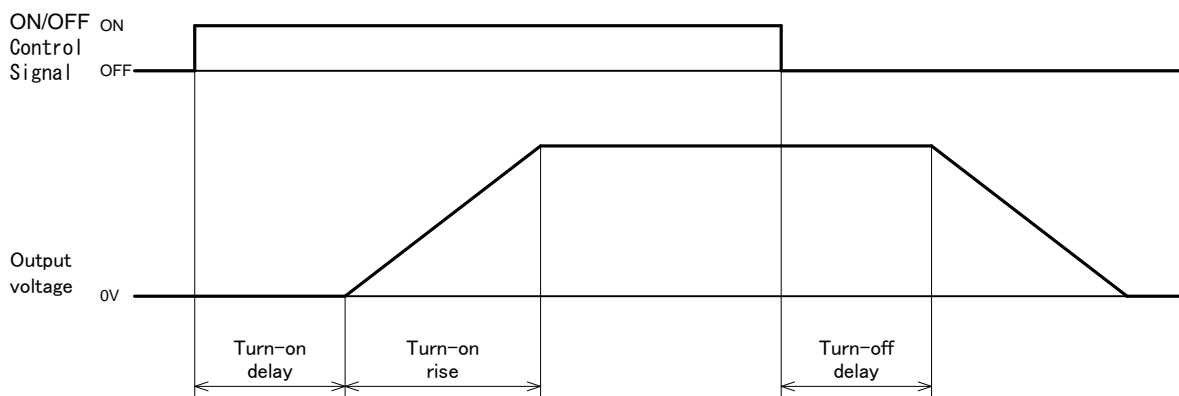

There is a delay of 10ms typ. until the turn-on sequence begins after the input. (See the figure below)

70µs typ. (setting as Turn-on Rise=1.3ms) of delay time appears when start-up by ON/OFF control.

Each setting of the sequence features can be configured via serial communication. However, turn-on rise may differ from the preset time depending on load capacity.

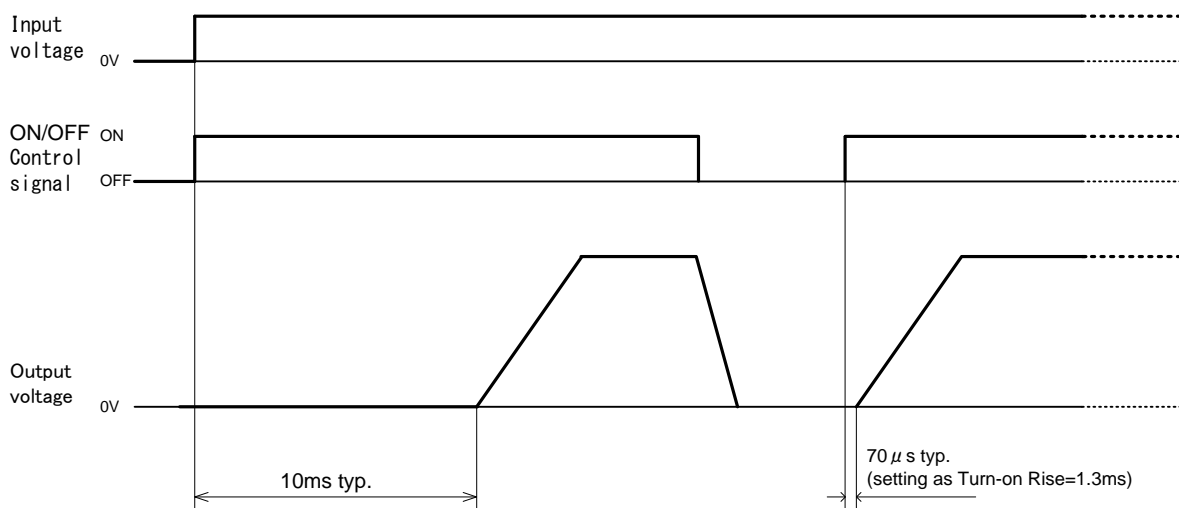

Items	PMBus commands	Setting range	Resolution	Default setting
Turn-on delay	TON_DELAY	0 to 500ms	0.016ms	0ms
Turn-on rise	TON_RISE	0.19 to 49.152ms	See formula below	1.3ms
Turn-off delay	TOFF_DELAY	0 to 500ms	0.016ms	0ms

Resolution of turn-on rise is calculated using a formula below.

$$\text{Resolution (ms)} = \frac{16384 \times A}{2^{n12} \times 64000}$$

A: Value using data word of the PMBus command, VOUT\_COMMAND (A 2-byte signed integer using two's complement)

Turn-off delay does not apply to the following cases.

- Turn-off sequence is disabled when output is turned off via serial communication
- Turn-off sequence is disabled when output is turned off via the ON/OFF pin.
- The converter is turned off by the following protection features (Under voltage lock out, Input overvoltage protection, Output overvoltage protection, Overcurrent protection, Thermal shutdown)

#### 8-9 Output voltage transition rate

This function allows output voltage transition rate to be configured via serial communication when changing output voltage.

Item	PMBus command	Range	Default setting
Output voltage regulation	VOUT_TRANSITION_RATE	0.012 to 3.125mV/us	1.043mV/us

Use formulas below to work out output voltage regulation.

$$B = \frac{64 \times 10^6}{20480 \times A} - 1$$

$$D = \frac{64 \times 10^6}{20480 \times (C+1)}$$

- A: Desired output voltage regulation (V/s)
- B: Variable number
- C: Variable number that is rounded off (0 to 255)
- D: Actual output voltage regulation (V/s)

#### 8-10 P-Good signal

This function allows output condition of the DC-DC converter to be monitored by using the PG pin which is an open drain output.

When output voltage remains within  $\pm 12.5\%$  of the preset value, the PG pin becomes open (High impedance) and if it goes outside the threshold, it becomes low (0.4V.max.).

A maximum voltage of up to 3.6V can be applied to the PG pin.

Sink current of the PG pin should remain less than 2.9mA.

Note1: The P-Good pin becomes low during voltage being changed when changing output voltage during operation.

Note2: P-Good signal may output when input voltage turn-on up to operation starting voltage.

## 8-11 Parallel operation function

Refer to application note.

## 8-12 Operation state monitoring

Input voltage, output voltage and output current of the product can be obtained via serial communication.

Detection accuracy for monitoring input voltage	±1% typ.
Detection accuracy for monitoring output voltage	±1% typ.
Detection accuracy for monitoring output current loading rate 20% to 100%)	±2A typ. (When ambient temperature 25°C±5°C,

The product contains 6 status registers, STATUS\_BYTE, STATUS\_WORD, STATUS\_VOUT, STATUS\_IOUT, STATUS\_INPUT, STATUS\_TEMPERATURE. Error status of the product can be detected by monitoring the status registers.

The status registers are set when the protection features are activated during operation. Contents of the status registers remain even after removal of the causes that set the status registers. Either one of the items stated below can clear the status registers.

- Execute the CLEAR\_FAULTS command
- Re-startup input

The contents of each register can be read out via serial communication.

Refer to the command list for each register in details.

Items	PMBus commands
Monitoring input voltage	READ_VIN
Monitoring output voltage	READ_VOUT
Monitoring output current	READ_IOUT
STATUS_BYTE register	STATUS_BYTE
STATUS_WORD register	STATUS_WORD
STATUS_VOUT register	STATUS_VOUT
STATUS_IOUT register	STATUS_IOUT
STATUS_INPUT register	STATUS_INPUT
STATUS_TEMPERATURE register	STATUS_TEMPERATURE



**8-13 Under Voltage Lock Out (UVLO)**

This function prevents the product from malfunctioning when input voltage drops. Input voltage of 7.5V typ. and over prepares for switching operation to start and input voltage of 7.0V typ. and under stops switching operation.

Note: UVLO may be activated depending on voltage tilt in degrees during power-up.

**8-14 Input overvoltage protection**

Input voltage of 15V typ. and over activates the overvoltage protection feature that stops switching operation. Input voltage of 14V typ. and under restarts switching operation.

Note: Refrain from inputting voltage that exceeds 14V which is out of specification.

Protection will not activate when input voltage exceed 14V ~ under 15V.

**8-15 Output overvoltage protection**

When output voltage (between the +S and –S pins) exceeds operation threshold of the output overvoltage protection feature, switching operation ceases and restarts after 2s typ.

This feature will not function if overvoltage state is caused due to breakage of the product.

Threshold of the output overvoltage protection can be configured via serial communication.

Item	PMBus command	Setting range	Resolution	Default setting
Threshold of output overvoltage protection	VOUT_OV_FAULT_LIMIT	0.6 to 1.6V	195uV	1.6V

Note: Applications that require sudden load current change may activate the output overvoltage protection depending on adjustment level of output voltage. To prevent this, output capacitors can be added.

**8-16 Output undervoltage detection**

Status registers will be set when output voltage (between the +S and –S pins) goes below operational threshold of this feature. It only detects output undervoltage and does not activate a protection feature.

The threshold of the output undervoltage detection can be configured via serial communication.

Item	PMBus command	Setting range	Resolution	Default setting
Threshold of output undervoltage detection	VOUT_UV_FAULT_LIMIT	0 to 1.5V	195uV	0V

Note1: Applications that require sudden load current change may activate the output undervoltage detection depending on adjustment level of the output voltage. To avoid this, output capacitors can be added.

Note2: Though the PMBus command includes “Fault\_Limit” in the name, there is no protection feature.

**8-17 Output overcurrent protection**

When output goes into an overcurrent state, switching operation will cease and restarts after 500ms typ.

Upon releasing the overcurrent state, switching operation will resume with output voltage.

Threshold of the output overcurrent protection can be configured via serial communication.

Item	PMBus command	Setting range	Resolution	Default setting
Threshold of output overcurrent protection	IOOUT_OC_FAULT_LIMIT	20 to 184A	2A	184A

Note1: Refrain from keeping an overcurrent state for a long period of time.

Note2: The preset threshold and an actual activation point may differ depending on product variability in characteristics.

**8-18 Thermal shutdown**

As switching operation ceases when the product temperature exceeds 115°C typ., the thermal shutdown feature will be activated.

9. Serial Interface

9-1 Definitions of Symbols and Terms

The symbols and terms used in Chapter 9 are defined as below.

Symbols or Terms	Definition
Byte	8 bits
Word	16 bits (2 bytes)
Set	Set bit to logic "1"
Clear	Set bit to logic "0"
Nnb	Number "nn" should be in a binary value
Nnh	Number "nn" should be a value in hexadecimal notation

9-2 Communication method

Serial interface of the product complies with PMBus Specification Revision1.2.

9-3 Communication pins

The PMBus communication pins (SDA, SCL, SALRT) should be connected to a 2.7 to 5.5V power supply by using a pull-up resistor or its equivalent method. Leave the PMBus communication pin open if serial communication is not used.

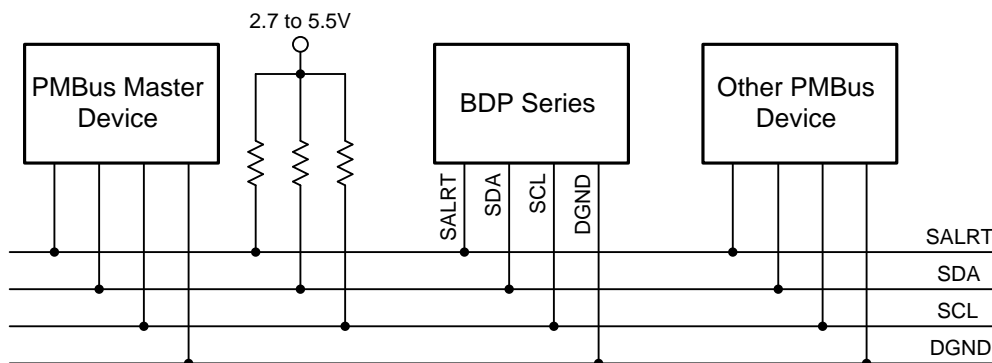

Note: Absolute maximum rating of PMBus communication pins (SDA, SCL, SALRT) are 5.5Vmax. Bus voltage defined as 3 to 5V±10% based on SMBus standard, the Bus voltage of PMBus communication pins are defined as 2.7 to 5.5V .

9-3-1 SDA pin

The SDA pin is a data input/output pin used for serial communication. The pin serves as an open drain output when data is output.

- Input low level: 0 to 0.8V
- Input high level: 2.1V min.
- Output low level: 0.4V max. (Sink current 4mA max.)

**9-3-2 SCL pin**

The SCL pin is a clock input pin used for serial communication. The SCL pin does not get driven by the product but by a bus master device.

Input low level: 0 to 0.8V  
 Input high level: 2.1V min.

**9-3-3 SALRT pin**

The SALRT pin is an abnormal signal output pin which serves as an open drain output. The pin is open in normal mode and low in abnormal mode

Output Low level: 0 to 0.4V

**9-4 Device address setup**

Each device can be identified by a device address since multiple devices share the same bus in the PMBus protocol. A unique device address should be given in order to avoid device address duplication on the same bus.

A device address can be specified by placing a resistor between the ADDR and AGND pins.

The following table shows resistor values and their corresponding device addresses. Each resistor should have a 1% tolerance.

A device address will be specified according to resistance value between the ADDR and AGND pins during power up. A device address will not change when resistance value between the ADDR and AGND pins is changed after power up. Thus input voltage requires to be set at 0V if you want to change a device address. Even when the communication feature is not used, make sure the ADDR pin is not OPEN.

Device address	Raddr [kΩ]	Device address	Raddr [kΩ]
0010 001	10.0	0011 100	56.2
0010 010	13.3	0011 101	61.9
0010 011	17.8	0011 110	68.1
0010 100	21.5	0011 111	75.0
0010 101	26.1	0100 000	82.5
0010 110	31.6	0100 001	90.9
0010 111	34.8	0100 010	100
0011 000	38.3	0100 011	110
0011 001	42.2	0100 100	121
0011 010	46.4	0100 101	133
0011 011	51.1	0100 110	147

## 9-5 Data format

## 9-5-1 Direct format

The data format comprises of elements indicated below.

- X: Actual value
- Y: Value using data word of the PMBus command  
(A 2-byte signed integer using two's complement)
- m: Tilt coefficient
- b: Off set value
- R: Exponential

\*Refer to details of each PMBus command instruction for value of m, b, R.  
The formula below shows links between the elements.

$$X = \frac{1}{m} (Y \times 10^{-R} - b)$$

$$Y = (m X + b) \times 10^R$$

## 9-6 PMBus commands

## 9-6-1 PMBus command list

The PMBus commands shown below can be used for the product.

PMBus commands	Command codes	Transaction type	Data length (Byte)	Data format	Default setting
OPERATION	01h	R/W Byte	1	—	04h
ON_OFF_CONFIG	02h	R/W Byte	1	—	17h
CLEAR_FAULTS	03h	Send Byte	0	—	—
STORE_DEFAULT_ALL*	11h	Send Byte	0	—	—
RESTORE_DEFAULT_ALL*	12h	Send Byte	0	—	—
VOUT_COMMAND	21h	R/W Word	2	Direct	0C00h (0.6V)
VOUT_TRIM	22h	R/W Word	2	Direct	0000h (0mV)
VOUT_MAX	24h	R/W Word	2	Direct	2000h (1.6V)
VOUT_MARGIN_HIGH	25h	R/W Word	2	Direct	0C00h (0.6V)
VOUT_MARGIN_LOW	26h	R/W Word	2	Direct	0C00h (0.6V)
VOUT_TRANSITION_RATE	27h	R/W Word	2	Direct	010Bh (1.043mV/us)
VOUT_OV_FAULT_LIMIT	40h	R/W Word	2	Direct	2000h (1.6V)
VOUT_UV_FAULT_LIMIT	44h	R/W Word	2	Direct	0000h (0V)
IOUT_OC_FAULT_LIMIT	46h	R/W Word	2	Direct	03AEh(184A)
TON_DELAY	60h	R/W Word	2	Direct	0000h (0ms)
TON_RISE	61h	R/W Word	2	Direct	002Bh (1.3ms)
TOFF_DELAY	64h	R/W Word	2	Direct	0000h (0ms)
STATUS_BYTE	78h	Read Byte	1	—	—
STATUS_WORD	79h	Read Word	2	—	—
STATUS_VOUT	7Ah	Read Byte	1	—	—
STATUS_IOUT	7Bh	Read Byte	1	—	—
STATUS_INPUT	7Ch	Read Byte	1	—	—
STATUS_TEMPERATURE	7Dh	Read Byte	1	—	—
READ_VIN	88h	Read Word	2	Direct	—
READ_VOUT	8Bh	Read Word	2	Direct	—
READ_IOUT	8Ch	Read Word	2	Direct	—

\*Use when output voltage is OFF.

The proper names of data formats in the transaction type indicated in the previous page are described below.

Transaction type	Communication protocol
Send Byte	Send Byte Protocol
Read Byte	Read Byte Protocol
Read Word	Read Word Protocol
R/W Byte	Read Byte Protocol and Write Byte Protocol
R/W Word	Read Word Protocol and Write Word Protocol

#### 9-6-2 OPERATION command (01h)

This command is used for the ON/OFF control and switching the margin states.

One data byte is one bit and meanings of each bit are described below.

Bits				Output ON/OFF	Margin State		Default setting
7-6	5-4	3-2	1-0				
00	XX	XX	XX	OFF	Margin OFF	Turn off sequence is disabled. Switching stops immediately	●
01	XX	XX	XX	OFF	Margin OFF	Turn-off sequence is enabled. Output is turned off via a sequence configured by TOFF_DELAY	
10	00	XX	XX	ON	Margin OFF	—	
10	01	01	XX	ON	Margin Low	Non usable	
10	01	10	XX	ON	Margin Low	—	
10	10	01	XX	ON	Margin High	Non usable	
10	10	10	XX	ON	Margin High	—	

Sections indicated by X have no effect on the operation regardless of whether they are 0 or 1.

A bit combination other than one of those specified above is not defined.

If the ON/OFF control is disabled via serial communication using the ON\_OFF\_CONFIG command(if bit 4 or 3 is cleared), the ON/OFF feature can not be controlled via this command.

## 9-6-3 ON\_OFF\_CONFIG command (02h)

This command is used to set the ON/OFF control operations.

One data byte is one bit and meanings of each bit are described below.

Bit No	Purpose	Value	Description	Default setting
7–5	Spare	Disregard	Invalid	
4	To select “ENABLE” or “DISABLE” of the ON/OFF control	0	Select “Disable” of the ON/OFF control via the ON/OFF pin and serial communication	
		1	Select “Enable” of the ON/OFF control via the ON/OFF pin and serial communication **	●
3	To select “ENABLE” or “DISABLE” of the ON/OFF control via serial communication	0	Select “Disable” of the ON/OFF control via serial communication	●
		1	Select “Enable” of the ON/OFF control via serial communication	
2	To select “ENABLE” or “DISABLE” of the ON/OFF control via the ON/OFF pin	0	Select “Disable” of the ON/OFF control via the ON/OFF pin	
		1	Select “Enable” of the ON/OFF control via the ON/OFF pin	●
1	—	1	Positive logic (Output is ON when Opened)	●
0	To select “ENABLE” or “DISABLE” of turn-off sequence when output is turned off via the ON/OFF pin	0	Output is turned off via a sequence configured TOFF_DELAY command	
		1	Switching stops immediately	●

\*\* Operation will follow the setting contents of Bit No. 0 to 3.

## 9-6-4 CLEAR\_FAULTS command (03h)

This command is used only to clear all the bits in a status register and contents of the status register remains until the causes are removed.

## 9-6-5 STORE\_DEFAULT\_ALL command (11h)

This command is used to store contents of the operating memory to the non-volatile user store memory.

Note: Make sure to keep the input voltage for 2 seconds after the command is executed.

## 9-6-6 RESTORE\_DEFAULT\_ALL command (12h)

This command is used to have contents of the non-volatile user store memory to be copied back to the operating memory.

## 9-6-7 VOUT\_COMMAND command (21h)

This command is used to configure output voltage when Margin state is Margin OFF. With direct format (Unit: V) the data length is 2 bytes. Coefficient is m=5120, b=0, R=0.



**9-6-8 VOUT\_TRIM command (22h)**

This command is used to set output voltage trimming. With direct format (Unit: V) the data length is 2 bytes. Coefficient is  $m=5120$ ,  $b=0$ ,  $R=0$ .

**9-6-9 VOUT\_MAX command (24h)**

This command is used to set a maximum limit of output voltage. With direct format (Unit: V) the data length is 2 bytes. Coefficient is  $m=5120$ ,  $b=0$ ,  $R=0$ .

**9-6-10 VOUT\_MARGIN\_HIGH command (25h)**

This command is used to set output voltage when Margin state is Margin high. With direct format (Unit: V) the data length is 2 bytes. Coefficient is  $m=5120$ ,  $b=0$ ,  $R=0$ .

**9-6-11 VOUT\_MARGIN\_LOW command (26h)**

This command is used to set the output voltage when Margin state is Margin Low. With direct format (Unit: V) the data length is 2 bytes. Coefficient is  $m=5120$ ,  $b=0$ ,  $R=0$ .

**9-6-12 VOUT\_TRANSITION\_RATE command (27h)**

This command is used to set output voltage tilts during operation. With direct format (Unit: mV/us) the data length is 2 bytes. Coefficient is  $m=256$ ,  $b=0$ ,  $R=0$ .

**9-6-13 VOUT\_OV\_FAULT\_LIMIT command (40h)**

This command is used to set a threshold of the output overvoltage protection. With direct format (Unit: V) the data length is 2 bytes. Coefficient is  $m=5120$ ,  $b=0$ ,  $R=0$ .

**9-6-14 VOUT\_UV\_FAULT\_LIMIT command (44h)**

This command is used to set a threshold of the output under voltage detection. With direct format (Unit: V) the data length is 2 bytes. Coefficient is  $m=5120$ ,  $b=0$ ,  $R=0$ .

**9-6-15 IOUT\_OC\_FAULT\_LIMIT command (46h)**

This command is used to set a threshold of the output overcurrent protection. With direct format (Unit: A) the data length is 2 bytes. Coefficient is  $m=5.12$ ,  $b=0$ ,  $R=0$ .

**9-6-16 TON\_DELAY command (60h)**

This command is used to set turn-on delay. With direct format (Unit: V) the data length is 2 bytes. Coefficient is  $m=62.56$ ,  $b=0$ ,  $R=0$ .

**9-6-17 TON\_RISE command (61h)**

This command is used to set turn-on rise. With direct format (Unit: V) the data length is 2 bytes. Coefficient is  $m=32$ ,  $b=0$ ,  $R=0$ .

**9-6-18 TOFF\_DELAY command (64h)**

This command is used to set turn-off delay. With direct format (Unit: V) the data length is 2 bytes. Coefficient is  $m=62.56$ ,  $b=0$ ,  $R=0$ .

## 9-6-19 STATUS\_BYTE command (78h)

This command is used to read the STATUS\_BYTE register which is a 1-byte register.

The chart below shows what each bit means.

Bit No	Bit name	Description
7	Reserved	0 at all times
6	OFF	1 when output is OFF (OFF by protection features as well as the ON/OFF control)
5	VOUT_OV	1 when overvoltage protection is activated
4	IOUT_OC	1 when overcurrent protection is activated
3	VIN_UV	1 when input voltage goes below the operation stop voltage of input under voltage lockout.
2	TEMPERATURE	1 when one of the STATUS_TEMPERATURE registers bits is 1
1	—	Undisclosed
0	—	Undisclosed

## 9-6-20 STATUS\_WORD command (79h)

This command is used to read the STATUS\_WORD register which is a 2 byte register.

The chart below shows what each bit means.

	Bit No	Bit name	Description
Low-order	7	Reserved	0 at all times
	6	OFF	1 when output is OFF (OFF by protection features as well as the ON/OFF control)
	5	VOUT_OV	1 when output overvoltage protection is activated
	4	IOUT_OC	1 when output overcurrent protection is activated
	3	VIN_UV	1 when input voltage goes below the operation stop voltage of input under voltage lockout.
	2	TEMPERATURE	1 when one of the STATUS_TEMPERATURE register bits is 1
	1	—	Undisclosed
	0	—	Undisclosed
High-order	7	VOUT	1 when one of the STATUS_VOUT register bits is 1
	6	IOUT	1 when one of the STATUS_IOUT register bits is 1
	5	INPUT	1 when one of the STATUS_INPUT register bits is 1
	4	—	Undisclosed
	3	POWER_GOOD#	Negative logic signal. 1 under conditions that P-Good pin becomes low.
	2	—	Undisclosed
	1	—	Undisclosed
	0	—	Undisclosed

## 9-6-21 STATUS\_VOUT command (7Ah)

This command is used to read the STATUS\_VOUT register which is a 1-byte register.

The chart below shows what each bit means.

Bit No	Description
7	1 when output overvoltage protection is activated 1 when output voltage is configured to a level where the preset value of the VOUT_MAX command
6	0 at all times
5	0 at all times
4	1 when output under voltage detection is activated
3	Undisclosed
2	Undisclosed
1	Undisclosed
0	0 at all times

## 9-6-22 STATUS\_IOUT command (7Bh)

This command is used to read the STATUS\_IOUT register which is a 1-byte register.

The chart below shows what each bit means.

Bit No	Description
7	1 when output overcurrent protection is activated
6	0 at all times
5	0 at all times
4	0 at all times
3	Undisclosed
2	Undisclosed
1	0 at all times
0	0 at all times

## 9-6-23 STATUS\_INPUT command (7Ch)

This command is used to read the STATUS\_INPUT register which is a 1-byte register.

The chart below shows what each bit means.

Bit No	Description
7	1 when input overvoltage protection is activated
6	Undisclosed
5	Undisclosed
4	1 when input under voltage protection is activated
3	0 at all times
2	0 at all times
1	0 at all times
0	0 at all times

**9-6-24 STATUS\_TEMPERATURE command (7Dh)**

This command is used to read the STATUS\_TEMPERATURE register which is a 1-byte register.

The chart below shows what each bit means.

Bit No	Description
7	1 when thermal shutdown feature is activated
6	Undisclosed
5	Undisclosed
4	Undisclosed
3	0 at all times
2	0 at all times
1	0 at all times
0	0 at all times

**9-6-25 READ\_VIN command (88h)**

This command is used to read input voltage of the DC-DC converter. With direct format (Unit: V) the data length is 2 bytes. Coefficient is m=1862, b=0, R=0.

**9-6-26 READ\_VOUT command (8Bh)**

This command is used to read output voltage of the DC-DC converter. With direct format (Unit: V) the data length is 2 bytes. Coefficient is m=640, b=0, R=0.

**9-6-27 READ\_IOUT command (8Ch)**

This command is used to read output current of the DC-DC converter. With direct format (Unit: V) the data length is 2 bytes. Coefficient is m=5.12, b=0, R=0.

10. Reverse polarity protection at the input (Example)

Inadvertently, reversing the polarity of the input connected to the product can lead to product damage. If there is a possibility that the polarity reversal may occur, add a protection circuit to the product.

The figure below is an example of a protection circuit using a fuse and diode.

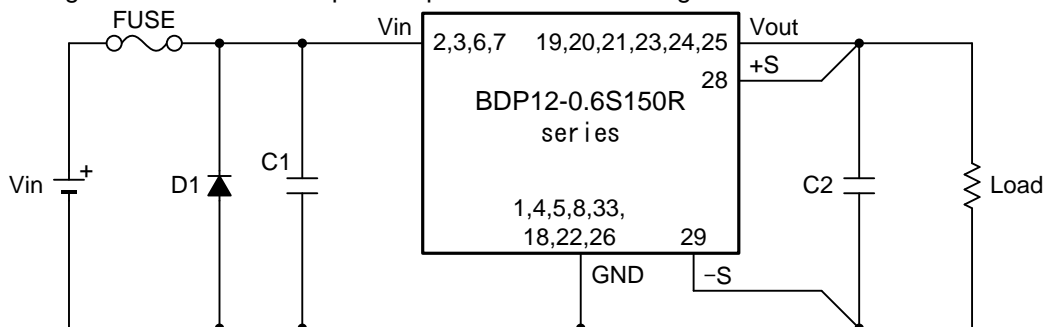

11. Overvoltage protection (Example)

The product comes with a built-in overvoltage protection function. However, if switch element in the product is damaged when in short circuit mode, the DC input voltage might still be delivered directly to the output side. Thus, an input shutoff circuit needs to be added to the product to prevent it from becoming damaged when in overvoltage mode.

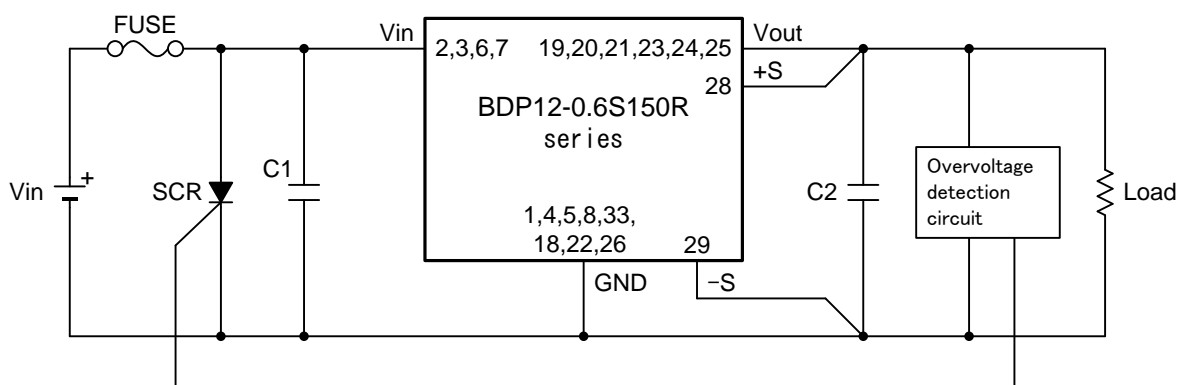

Note1: If the converter is damaged when in overvoltage mode, the ON/OFF control can not be operated.

Note2: If there is an ON/OFF feature for power source of the converter, the function can be used.

Note3: Allow enough capacity in the DC power supply for a fuse to blow.

## 12. Mounting requirements

The following conditions will apply to soldering temperature, time and storing before mounting.

### Re-flow method

- Pre-heat temperature: 150 to 180°C, 120s max. (See the figure below)
- Peak temperature: 250°C max.
- Re-flow count: 1

Refrain from giving vibrations during reflow, for it may cause converter components to move.

After mounting the converter onto a board, reflow can not be made again by turning over the mounted boards.

Flow mounting is not possible for the product.

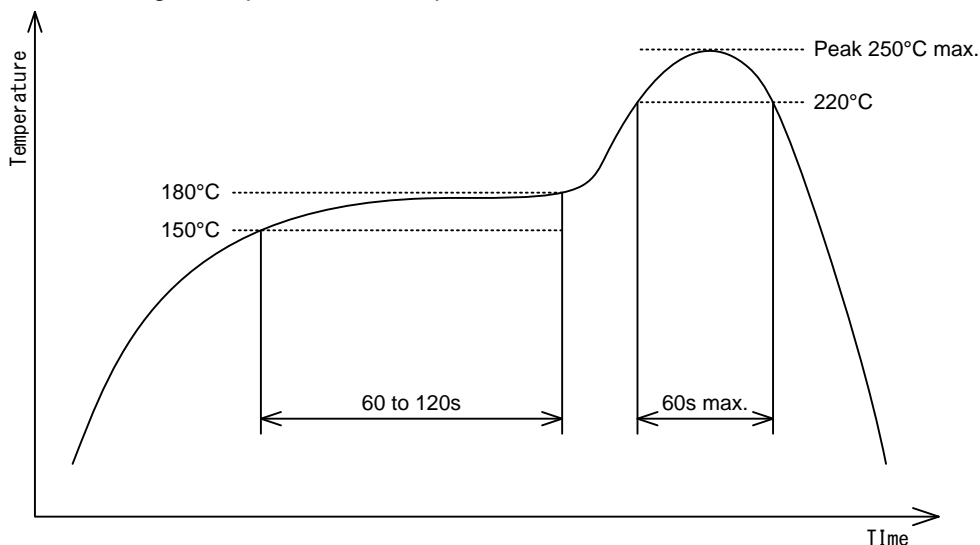

### 12-1 Storage before mounting

Humidity control level for the product is JEDEC MSL3.

If a dry pack is opened, store at an ambience below 30°C/60%R.H.

If the product is kept in an unopened package for one year or kept in an opened dry package at an ambience below 30°C/60%R.H. for 168 hours, baking (125°C±5°C/24h) is required before reflow process.

After installing the product, handle it in accordance with the storage requirements.

### 13. Vibration and Shock Testing

Vibration: 5 to 10Hz, Total amplitude 10mm, 10 to 55Hz, Acceleration 2G (One hour for each of the three directions)

Shock: Acceleration 20G (three times for each of the three directions), Shock time 11 ± 5ms

### 14. Cleaning

The product is not for immersible cleaning. Use of no-clean flux is recommended.

#### 15 Precautions for use

To ensure user's safety, check specifications before using the product and always observe the following precautions for use.

- The product is intended for use in general electronics equipment (office equipment, communication equipment, measurement equipment). Do not use the product for medical equipment, nuclear equipment, trains, etc., whereby human life or property may be directly affected by a damaged product. Consult with us for any use other than for such general electronics equipment.
- Minor changes and component parts changes that do not affect contents of the specifications will be made due to characteristic improvement of the product and other reasons without prior notice.
- The product is not suitable for series operation.
- Do not use connectors and sockets for mounting the product. Contact resistance may have an adverse effect on the performance. Use soldering method for mounting on a printed circuit board.
- The product supports for high current. Pattern or wiring can become higher temperature when current gets large. Current value must take sufficient measures when setting an evaluation environment and when designing the surrounding layout etc.
- The product has a built-in overcurrent protection circuit but avoid a prolonged short circuit state which may lead to failure.
- The product may be damaged if used under nonstandard electrical conditions or nonstandard environmental conditions including temperature. Ensure use within the standards.
- Avoid storing or using the product in a place that generates corrosive gas or dust.
- The product may be damaged by static electricity. Make sure that the workplace is guarded against static buildup and static electricity on operators by use of proper grounding.
- A fuse mechanism is not built in the product. Connect a fuse to the + input line to guard against excessive input current under abnormal circumstances. Allow enough capacity in the power supply for a fuse to blow.
- The product has overvoltage protection. If overvoltage occurs due to abnormality in the module, input voltage is output, as is, in the same mode, which may result in fumes and ignition. Make sure that an overvoltage protection circuit is added to prevent it from occurring.
- The product does not come with a test report.
- The product is subject to the license from Power-one which is related to the patented digital power technology owned by Bel Fuse Inc.

#### 16. Warranty

The warranty term of the product is one year after shipment. Should the product become defective within the warranty period due to our design or workmanship, the product will be repaired free of charge or replaced. However, this warranty does not cover products which have been subjected to unauthorized inner modifications, etc.

The scope of our warranty is limited to that of the said product.

#### 17. Contact

If you have any further technical questions for this product, please contact us.

E-mail: [info@bellnix.com](mailto:info@bellnix.com)

URL: <http://www.bellnix.com>